

The Vertikal Guide

for buyers and users of lifting equipment

para compradores y usuarios de equipos de elevación



Cranes

Telehandlers

Aerial Lifts

Grúas

Manipuladores

Telescópicos

Plataformas

www.vertikal.net

Vertikal days

a meeting of minds.....
for lifting equipment professionals

Haydock Park Racecourse
Wednesday **25th** & Thursday **26th** June **2008**



Vertikal Days is a two day event focusing solely on the lifting equipment industry, where professionals with an interest in Cranes, Access equipment or Telehandlers can meet with suppliers and other industry professionals as well as view the latest products and services.

For information on how to register -
visit our website www.vertikaldays.net
email the Vertikal Team at info@vertikaldays.net

Telephone: UK **+44 (0) 8707 740436** • Germany **+49 (0) 761 89786615**

www.vertikal.net

Vertikal

Editors:

Mark Darwin
Rüdiger Kopf
Alexander Ochs
Macarena Garcia



Advertising & Sales:

Karlheinz Kopp
Pam Penny

Production:

Nicole Engesser

Publisher:

Leigh W. Sparrow

The Vertikal Press Ltd.

PO box 6998 Brackley
NN13 5WY. UK
Tel: +44(0)8707 740436
Fax: +44(0)1295 768223
E-mail: info@vertikal.net

Vertikal Verlag

Sundgaualle 15, D-79114,
Freiburg, Germany
Tel: +49 761 8978660
Fax: +49 761 8866814
E-mail: info@vertikal.net

Vertikal Russia

DM Publishing 127287 Pocc
Moscow.
Tel: +7 (495) 685 9428
Fax: +7 (495) 685 9429
E-mail: matrosova@vertikalnet.ru

Design & Artwork by:

bp design
Tel: +44 (0) 1707 642141
Fax: +44 (0) 1707 646806
E-mail: studio@bpdesign.info

© The Vertikal Press Ltd. 2008

From the publisher of:

**cranes
& access**

**Kran &
Bühne**

**Vertikal
.net**

Interesting times

It hardly seems like three years since we were all here for the last Conexpo, but it is and much has happened since then. As the doors open on the largest construction equipment show in North America, the Access and Lifting industries face interesting times. The three main product categories we cover, Cranes, Aerial lifts and Telehandlers are all doing well on a global basis, although the US telehandler market has undoubtedly been affected by the slow down in the housing market and lead times for aerial lifts are not as long as they were.



When large exhibitions occur during periods of uncertainty such as this, the opportunities they offer buyers senior managers to meet with the main manufacturers to discuss the year ahead and strategies are more valuable than ever.

This year's show is without doubt the biggest Conexpo so far and a large number of producers are introducing new and improved models to their lines. You might also glimpse of and be asked to comment on some new products and services currently on the drawing board.

With all the hustle and bustle of a big international show it is very easy for both visitors and exhibitors to miss the opportunities it offers. We hope that our guided show tours and clear maps will help save time and inform you. And when the show closes in the evening don't forget to check out the pages on Las Vegas. Do stop by and see us on stand S-555 between the Silver and Gold lots.

Leigh W Sparrow

Tiempos interesantes

Parece increíble que ya hayan pasado tres años desde la última edición de Conexpo, pero así es y han pasado muchas cosas desde entonces. Mientras se abren las puertas de la feria más grande de equipos de construcción de Norteamérica, la industria de la elevación vive momentos interesantes.



Las tres categorías más importantes que cubrimos, Grúas, Plataformas Aéreas y Manipuladores Telescópicos están atravesando un buen momento a nivel global, aunque el Mercado Americano de los manipuladores telescópicos se ha visto afectado por la ralentización en el Mercado inmobiliario y los tiempos boyantes de las PEMP no son lo que eran.

Cuando las ferias se celebran durante estos periodos de incertidumbre, la oportunidad que se brinda de poder hablar con los directores de los principales fabricantes para discutir sobre el futuro y sus estrategias es muy valioso.

Este año es sin duda el año más grande de Conexpo hasta ahora y un gran número de fabricantes presentarán nuevos y mejorados modelos en sus líneas. También podrá conocer las futuras novedades que presentarán los fabricantes en el futuro.

Con el trájín que supone una feria como Conexpo es fácil que tanto los visitantes como expositors pierdan oportunidades magnificas que la feria ofrece. Pore so esperamos que esta guía que les ofrecemos con mapas muy claros sirva como herramienta de trabajo para ahorrarle tiempo y le informe puntualmente de todas las novedades. Cuando la feria cierra sus puertas por la tarde, no olvide consultar las páginas sobre Las Vegas.

Leigh W Sparrow



¡Instruyamos
también en español!

Aerial platforms



AWPT trained operators



Safer effective work at height



The IPAF training program is the most successful and widely recognized in the world. It has already trained thousands and thousands of operators in the safe and productive use of modern platforms – and its PAL Card is recognized everywhere as proof of high quality training.

This training is available in North America from AWPT-approved training centers. AWPT is IPAF's North American subsidiary. Safety legislation everywhere increasingly demands training to a recognized level and the AWPT program meets or exceeds the intent of the new international standard, ISO 18878.

Your business relies on the productivity of your operators as well as safety. So insist on market leading operator training for operators to get every job at height done effectively and with maximum safety.

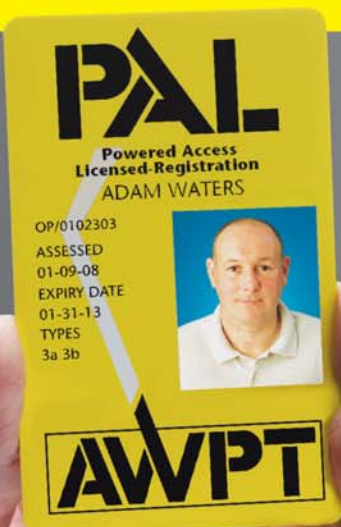

Contact us for full details now

Call +1 518-280-2486

Email mail@awpt.org

- Find your nearest AWPT Training Center
- Learn how to become an AWPT Training Center
- Discover how to join AWPT and how AWPT can help your business

Aerial Work Platform Training, Inc. 225 Placid Drive,
Schenectady, NY 1230

AWPT operator training meets or exceeds OSHA and ANSI standards



Promoting the safe and effective use of powered access

A subsidiary of IPAF



www.awpt.org



Visit the IPAF Safety Zone at CONEXPO
Booth SZ1000, Green Lot



- 3** Introduction • Introducción
- 6/10** Exhibition plans • Planos de exhibición
- 13/15** Exhibitor list • Lista de expositores
- 17** All terrain/Truck-Mounted cranes
 - Grúas todo terreno
- 19** Rough Terrain cranes
 - Grúas para terrenos accidentados
- 21** Crawler cranes • Grúas de celosía
- 23** Tower/trailer cranes • Grúas torre
- 24/25** AWPT/IPAF
- 27** Self propelled booms
 - Plataformas autopropulsadas
- 31** Scissor lifts • Plataformas de tijera
- 33** Trailer lifts • Plataformas remolcables
- 35** Truck mounted lifts • Plataformas sobre camión
- 37** Mast climbers • Plataformas de másti
- 39** Telehandlers • manipuladores telescópicos
- 43** Truck loader cranes
 - Grúas hidráulicas sobre camión
- 45** Remote controls • Control remoto
- 47** Components • Componentes
- 49** Tower crane safety • Seguridad en grúas torre
- 50** Map of Las Vegas • Mappa Las Vegas
- 51** Sights of Las Vegas
 - Puntos de interés de Las Vegas
- 53** Getting around Las Vegas
 - Moverse por Las Vegas
- 54** Restaurants and bars • Restaurantes and bares
- 56** Las Vegas shows • Espectáculos
- 57** It is gaming not gambling • Se trata de jugar
- 58** Golf courses • Campos de golf
- 59** Further away • Más allá
- 60** Marketplace





CONEXPO 2008 MARCH 11-15

AWPT/ IPAF

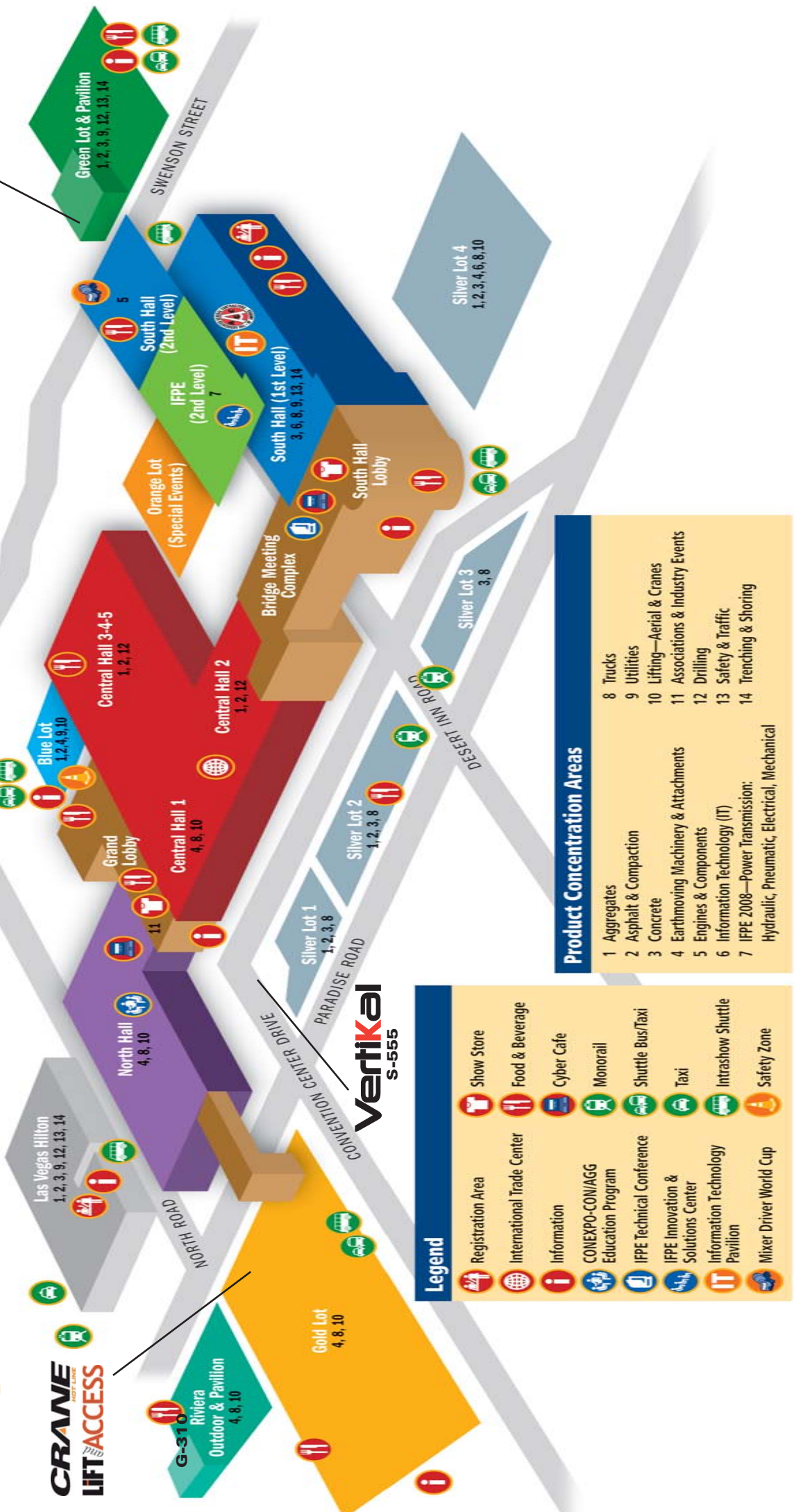

CRANE
LIFTACCESS

Vertikal
S-555

Legend

- Registration Area
- International Trade Center
- Information
- CONEXPO-CON/AGG Education Program
- IPFE Technical Conference
- IPFE Innovation & Solutions Center
- Information Technology Pavilion
- Mixer Driver World Cup
- Show Store
- Food & Beverage
- Cyber Cafe
- Monorail
- Shuttle Bus/Taxi
- Taxi
- Intrashow Shuttle
- Safety Zone

Product Concentration Areas

- 1 Aggregates
- 2 Asphalt & Compaction
- 3 Concrete
- 4 Earthmoving Machinery & Attachments
- 5 Engines & Components
- 6 Information Technology (IT)
- 7 IPFE 2008—Power Transmission: Hydraulic, Pneumatic, Electrical, Mechanical
- 8 Trucks
- 9 Utilities
- 10 Lifting—Aerial & Cranes
- 11 Associations & Industry Events
- 12 Drilling
- 13 Safety & Traffic
- 14 Trenching & Shoring

See us at
CONEXPO
Booth G-170

UNLEASH THE POWER OF ORANGE

THERE'S NO TIME FOR DOWN TIME. You need lift equipment to do your job. If your machines don't work, you don't work. JLG gets that. We do more, reach higher and stretch further to make sure you're up and running. Whenever and wherever you need to be. With JLG, you get a higher level of performance, reliability, service, and parts support to keep you and your equipment working. Day in and day out. Year after year. You don't have time to be tied down. So unleash the power of JLG.

An Oshkosh Corporation Company

877-JLG-LIFT | www.jlg.com/unleash45

JLG[®]

GOLD LOT

CRANE LIFT ACCESS

Stand No.s 300s

Stand No.s 300s

GOLD LOT KEY

- POWERED ACCESS
- CRANES
- TELEHANDLERS
- COMPONENTS

G-370 **Liebherr**

G-366 **Solideal**

G-353 **Manitowoc**

G-339 **G-336** **Feterl**

G-338 **Alimak Hek**

G-325 **Hydra Platforms**

G-314 **G-312** **G-309** **NW Equipment**

G-304 **G-307** **G-305** **G-300**

G-335 **Hochmann** **AUSA**

G-330 **Manitex**

G-320 **Kobelco**

G-341 **McLellan Equipment** **G-340** **Rancco Trailers**

G-343 **G-342**

G-364 **G-363** **G-362** **Efoo Corp.**

G-360 **Indexator**

G-258 **G-259** **Palladin** **Pettibone**

G-248 **Elliot Equipment**

G-236 **Haulotte**

G-230 **G-220** **Stellar Industries** **Allu Group**

G-240 **Link Belt**

G-251 **G-250**

G-260 **Doosan Infracore**

G-278 **G-275** **G-276** **Altec Industries**

G-270 **Altec Industries**

G-286 **G-280**

G-285 **G-290**

Stand No.s 200s

Stand No.s 200s

G-156 **Fushon Excavator Corp.**

G-147 **Xtreme Manufacturing**

G-137 **Alamo Group**

G-129 **G-127** **G-122** **Snorkel/UpRight**

G-100 **Bobcat**

G-150 **LBX**

G-140 **Caterpillar**

G-134 **Volvo Construction Equipment**

G-130 **Ingersoll Rand**

G-160 **JCB Inc.**

G-175 **Trail King Industries**

G-195 **Manitou**

G-170 **JLG**

G-184 **G-180**

G-196 **G-194** **G-192** **G-191** **G-190** **GM Fleet**

Stand No.s 100s

Stand No.s 100s



A FULL LINE SUPPLIER OF AERIAL WORK PLATFORMS



March 11-15
LAS VEGAS-USA

BOOTH G-236

BLUE LOT



BLUE LOT KEY

	POWERED ACCESS
	CRANES
	TELEHANDLERS
	COMPONENTS

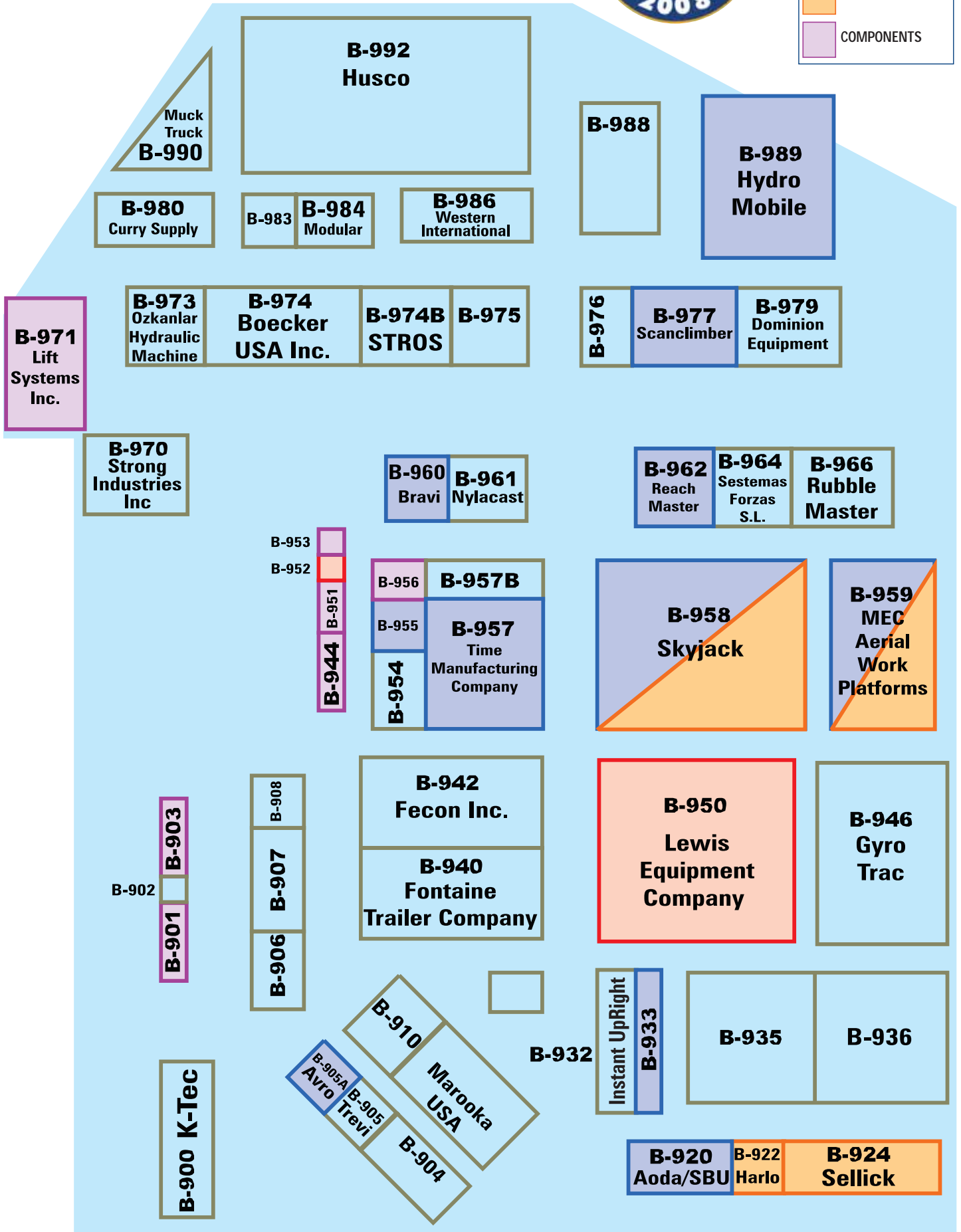



THE COLOR OF

confidence

Genie is a name you can depend on for the most advanced lifts in the industry. With quality built into every step of the manufacturing process, you are assured exceptional performance for your most demanding jobs.

Plus, every Genie comes with 24/7 service and support from people who know your business. Be confident in your equipment choice, **Think Blue.**

1-800-536-1800

EMAIL info@genieind.com | WEB genieindustries.com



STILL THE BEST. STILL THE ORIGINAL. AND ABOVE ALL, STILL THE SAFEST!

ReachMaster Falcon



ReachMaster Hinowa



ReachMaster MMTM-100



100' LIFT ON A 19000 GVWR TRUCK!!!

ReachMaster Basic



When you buy a ReachMaster, you buy a lot more than just a lift!

Features include:

- Working heights from 46' to 138'
- Access through a single door
- Self propelled
- Dual power
- Track and wheel based
- In and outdoor use
- Self loading
- Unsurpassed outreach

U.S. based services include:

- Project Consulting
- Factory trained technicians
- Spare parts inventory
- Operational and technical training

**NEW PRODUCT
SPECIAL PREVIEW AT**

ConExpo-Con/AGG,
Las Vegas, NV
March 11-15, 2008
ReachMaster
Booth B-962
(Blue Lot)



ReachMaster, Inc.
Toll-free 1-866-358-7088
www.reachmaster.com



STAND	HALL/LOT
Self-propelled Booms • Plataformas autopropulsadas	
Aichi	S-8907 South
Bil-Jax	S-8417 South
Genie/Terex	G-200 Gold
Haulotte	G-236 Gold
Hinowa	S-16200/B-962 Silver/Blue
Italmecc Manlifts	C-7107 Central
JLG	G-170 Gold
Loeering	C-5796 Central
Manitou	G-195 Gold
MEC	B-959 Blue
Niftylift	SZ-1000
PM/Oil & Steel	RL-43033
ReachMaster	B-962 Blue
Skyjack	B-958 Blue
Snorkel	G-117 Gold
UpRight	G-117 Gold
Worldlift	B-962 Blue
Mast Booms • Elevadores de Mástil	
Haulotte	G-236 Gold
JLG	G-170 Gold
Manitou	G-195 Gold
Snorkel	G-117 Gold
UpRight	G-117 Gold
Push Around lifts • Elevadores de empuje manual	
Bil-Jax	S-8417 Silver
Genie/Terex	G-200 Gold
JLG	G-170 Gold
UpRight	G-117 Gold
Scissor lifts • Plataformas de Tijera	
Aichi	S-8907 South
Bil-Jax	S-8417 South
Bravi Platforms	B-933 Blue
Custom Equipment	B-955 Blue
Genie/Terex	G-200 Gold
Haulotte	G-236 Gold
JLG	G-170 Gold
Manitou	G-195 Gold
MEC	B-959 Blue
Pop-Up	
Skyjack	B-958 Blue
Snorkel	G-117 Gold
UpRight	G-117 Gold
Trailer & Spider lifts • Plataformas Remolcables y de araña	
Bil-Jax	S-8417 Silver
Denka	B-962 Blue
Genie/Terex	G-200 Gold
Haulotte	G-236 Gold
Hinowa	S-16200/B-962 South/Blue
Italmecc	C-7107 Central
JLG	G-170 Gold
PM/Oil & Steel	RL-43033
Reachmaster	B-962 Blue
Snorkel	G-117 Gold
UpRight	G-117 Gold
Worldlift	B-962 Blue
Truck/Van Mounts • Plataformas sobre camión	
Altec Industries	G-270 Gold
Böcker	S-614-4 Silver
Elliot Equipment	G248 Gold
Hydra	G-324 Gold
Palfinger	S-610 Silver
PM/Oil & Steel	RL-43033
Reachmaster	B-962 Blue
Terex Utilities	G-200 Gold
Time Condor Versalift	B-957 Blue
Versalift	B-957 Blue
Mast Climbers and hoists • Plataformas de Mástil	
Alimak Hek	G-336 Gold
Avro Hoist Company	B-905A Blue
Baoda Engineering Machinery/SBU Hoist	B-920 Blue
Böcker	S-614-4 Silver
Camac	G192 Gold
Fraco	GP-50439
Hek	G-336 Gold
Hydro Mobile	RL-42001
Scanclimber/Scaninter	B-977 Blue
Stros	B-974 Blue
Tractel	GP-50844
Wuxi Shenxi	C-7269C Central
Crawler Cranes • Grúas de celosía	
Fushun	G-156 Gold
Jekko	RL-41030
Kobelco	G-320 Gold
Lampson International	B-952 Blue
Lewis Equipment	B-950 Blue
Liebherr	G-374 Gold
Link Belt	G-240 Gold
MAIT Spa	S-734 Silver
Maeda	G-277 Gold
Manitowoc	G-353 Gold

STAND	HALL/LOT
Sany Heavy Industries	S-634 Silver
Terex	G-200 Gold
Tes Car	S-19135 Silver
Unic	RL-44013
XCMG	S-800 Silver
Xuzhou-Intensus	S-800 Silver
Zoomlion Heavy Industries	S-8239 Silver
All Terrain Cranes • Grúas todo terreno	
Faun Tadano-Faun	G-328 Gold
Grove	G-353 Gold
Lewis Equipment	B-950 Blue
Liebherr	G-374 Gold
Link Belt	G-240 Gold
Tadano	G-328 Gold
Terex-Demag	G-200 Gold
XCMG	S-800 Silver
Zoomlion Heavy Industries	S-8239 Silver
Rough Terrains • Grúas para terrenos accidentados	
Bendini Terex	G-200 Gold
Link Belt	G-240 Gold
Grove	G-353 Gold
PPM Terex	G-200 Gold
Tadano	G-328 Gold
Terex	G-200 Gold
Industrial Cranes • Grúas industriales	
Broderson	G-127 Gold
Grove	G-353 Gold
Lift Systems	B-971 Blue
Shuttlelift	G-363 Gold
Tower Cranes • Grúas Torre	
Comedil Terex	G-200 Gold
Jaso	S-553 Silver
Lewis Equipment	B-950 Blue
Linden Comansa	G-380 Gold
Liebherr	G-374 Gold
Peiner Terex	G-200 Gold
Potain	G-353 Gold
Sun Crane	B-950 Blue
Terex	G-200 Gold
Wolffkran	C-4033-6 Central
Zoomlion Heavy Industries	S-8239 Silver
Trailer cranes • Grúas remolcables	
Böcker	S-614-4 Silver
Spider cranes • Grúas	
Jekko	RL-41030
Maeda	RL-45023
Unic	RL-44013
Truck Loaders • Grúas hidráulicas	
Atlas -Terex	G-200 Gold
Altec Industries	G-270 Gold
Auto Crane	C-4233 Central
Elliot Equipment	G248 Gold
Heila Truck Loaders	C-7107 Central
Hiab	RL-45013
Iowa Mold Tooling	N-2141 North
Manitex	G-330 Gold
Palfinger	S-610 Silver
PM	RL-43033
Stellar Industries	G-230 Gold
Summit Truck Equipment	N-2859 North
Tadano	G-328 Gold
Terex	G-200 Gold
Unic	RL-44013
Telehandlers • Manipuladores Telescópicos	
Bobcat	G-100 Gold
Carelift	G-300 Gold
Case Construction Equipment	N-1609 North
Caterpillar	G-140 Gold
Faresin Handlers	RP-34005
Gehl	N-2601 North
Genie/Terex	G-200 Gold
Gradall Industries	G-137 Gold
Harlo Products Corp	B-922 Blue
Haulotte Group	G-236 Gold
Hinowa	S-16200 Silver
Hunan Sunward Intelligent Machinery	N-1041 North
JCB	G-160 Gold
JLG	G-170 Gold
Komatsu America Corp	N-1009 North
Liebherr	G-374 Gold
Lull	G-170 Gold
Manitou	G-195 Gold
MEC	B-959 Blue
Mustang	N-2741 North
New Holland Construction	G-120 Gold
Pettibone	G-259 Gold
Sellick Equipment	B-924 Blue
Skyjack	B-958 Blue
Skytrak	G-170 Gold
Taylor Machine Works	C-6513 Central
Terex	G-200 Gold
Xtreme	G-147 Gold
Zoom Boom - Carelift	G-300 Gold





ConExpo Booth # S8907
South Hall Level 1



Out Our New Products

Aichi Introduces
The All New



SKYMASTER
Boom Lifts



SKYTOWER
Scissor Lifts



GET ON
TRACK



Distributed by: AICHI U.S.A. INC.

1126 Crain Hwy NW Glen Burnie, MD 21061 Phone: 410-590-1134

Email inquiries to: alandotts@aichiusa.com

website: www.aichiusa.com

STAND	HALL/LOT
Remote Controls • Control Remoto	
Autec	S-10711 Silver
Cavotec	C-7590 Central
Crane Boss	GP-51242
HBC Radiomatic	G-122 Gold
Hetronic	G-338 Gold
Ikusi	C-4369 Central
Omnex	C-4259 Central
Robinson Engineering	GP-51242
Tele Radio	RP-37032

Electronics & Safety • Electrónica & Seguridad	
Ascotel	S-12321 Silver
Brigade Electronics	S-17801 Silver
Crane Dispatch Software	N-1300 North
3B6	S-18127 Silver
Cranesmart Systems	G-193 Gold
H J Hirtzer & Associates	S-847 Silver
Hirschmann	G-335 Gold
Ikusi	C-4369 Central
Itowa	S-18004 Silver
Kruger - Hirschmann	G-335 Gold
Laser Technology	C-6286 Central
Load Systems International	G-196 Gold
Loadwise	C-4867 Central
Moba	S-16530 Silver
McKee Communications	C-4029 Central
Omnex Control Systems ULC	C-4259 Central
Orlaco	B-953 Blue
PAT - Hirschmann	G-335 Gold
Rayco-Wylie Systems	B-944 Blue
SMIE	B-901 Blue
Trimble	S-17411 Silver

Tyres/Tires • Neumáticos	
Amerityre	RP-31001
Balkrishna Tyres	S-12019 Silver
Bridgestone Firestone	N-2301 North
Carpenter Company	GP-50919
Double Coin/CMA	S-12621 Silver
Gaither Tool Company	GP-50703
Goodyear	C-6769 Central
Michelin	N-2763 North
Solideal	G-366 Gold
Titan/General OTR	S-12101 Silver
Yokohama Tire	S-8729 Silver

Engines • Motores	
Cummins	S-16013 Silver
Deutz	S-16538 Silver
Hatz Diesel	S-16405 Silver
Kubota Engine	S-16049 Silver
Mitsubishi Engine	S-17627 Silver
MTU Detroit Diesel	S-16127 Silver
Perkins Engines	S-15927 Silver
Southwest Products Corp	S-8551 Silver
Volvo	G-134 Gold

Components • Componentes	
American Crane & Tractor Parts	H-24017
Atlanta Trading Company	GP-50607
Berco	N-2902 North
Cavotec	C-7590 Central
Centranz	GP-51329
Conveyor Components	C-6338 Central
Brevini	S-15327 Silver
Bosch Rexroth	S-13013 Silver
Dana Corporation	S-16313 Silver
Dica	S-9821 Silver
Double Coin/CMA	S-12621 Silver
EBC Industries	S-17827 Silver
Friction Marketing	C-4759 Central
Getz Enterprises	S-12431 Silver
Gosan Crane Components	C-4743 Central
IMO USA	C-4033-8 Central
Lube-A-Boom	S-550 Silver
Mailhot Industries	GP-50829
North American Hydraulics	S-13819 Silver
Optima Batteries	S-17330 Silver
Opus Electronics Inc	C-4033-11 Central
Oriental Engineering Works	S-17713 Silver
Partsmaster	C-4947 Central
Pirtek	S-17819 Silver
Power-Packer	S-17911 Silver
Samek Corporation	GP-50245

STAND	HALL/LOT
Simplex	S-17231 Silver
Solideal	G-366 Gold
SSAB Hardox	C-4168 Central
Tifco Industries	S-17408 Silver
Timco	B-951 Blue
Track One	S-12807 Silver
Tulsa Winch	C-6313 Central
Wachendorff Elektronik	C-4033-11 Central
ZF Industries	S-16039 Silver

Lifting Equipment • Equipos de elevación	
Actek Mfg & Eng	GP-50509
Alturamats	S-11407 Silver
ARI-HETRA	GP-50629/RL-44030
Arrow Material Handling Products	B-903 Blue
Auto Crane	C-4233 Central
Böcker	S-614-4 Silver
BVA Hydraulics	S-17431 Silver
Caldwell Group	S-9145 Silver
Crosby Group	C-4455 Central
Enerpac	S-17005 Silver
Extreme Outback Products	S-12310 Silver
F & M Mafco	S-18027 Silver
Feterl Manufacturing Corp	G-387 Gold
Gunnebo Johnson	G-307 Gold
Hyda-Tech International	S-16253 Silver
Hydraulic Power Systems	S-884 Silver
iHC Fundex Equipment	S-19100 Silver
Independent Parts & Service (IPS)	C-4345 Central
Kinshofer Liftall	S-19101 Silver
Kundel	C-4432 Central
Lift Equipment	GP-51011
Lift Systems Inc	B-971 Blue
Lift-All Co	GP-50739
Lifting Technologies	G-325 Gold
Lug-All	S-9928 Silver
Miller Products	C-7589 Central
Noblelift Equipment	C-7269B Central
Palfinger	S-610 Silver
Ramsey Winch	RP-36017
RGC/Reimann & Georger	S-8833 Silver
Rope Block	RL-45023
Rotzler Inc	C-6282 Central
Sellstrom Manufacturing Co	H-23026
Sicoma North America	S-8852 Silver
Signature Fencing & Flooring	GP-50809
Spanco	S-9928 Silver
Stertil-Koni	B-956 Blue
SwapLoader	G-301 Gold
Thern	S-9145 Silver
Wimag	S-614-3 Silver

Wire Rope • Cables	
Bethlehem - Wirerope Works	C-4913 Central
Bridon American	C-4027 Central
Casar - WireCo	C-4459 Central
Extreme Outback Products	S-12310 Silver
Lift-All Co Inc	GP-50739
Twin City Wire	C-7573 Central
WireCo	C-4459 Central
WRCA - WireCo	C-4459 Central
Wirerope Works	C-4913 Central

Trailers • Remolques	
Beall	RL43013
Cozad Trailer Sales	S-858 Silver
Landoll	S-758 Silver
Manac Trailers	G-191 Gold
MUV All Trailers - Palomino	H-23014
Ranco Trailers	G-340 Gold
Scheuerle	C-4033-5 Central
Trail Eze	G-278 Gold
Trail King	G-175 Gold
X-L Specialized Trailers	G-280 Gold

Associations/Services • Asociaciones	
ARA American Rental Association	L3216
ANMOPyC - Spanish Manu. Ass	L-3527
AWPT	SZ-1000
IPAF	SZ-1000
Material Handling Ind. of America	L-3511
NCCCO	L-3102
Ritchie Bros	N-2041 North
Vertikal Conexpo	S-555 Silver
Vertikal Press	S-555 Silver
Wynne Systems	S-10917 Silver



Manufacturer • Fabricante	Stand
Faun (Tadano-Faun)	G-328
Grove G-353	
Lewis Equipment	B-950
Liebherr	G-374
Link Belt	G-240
Tadano	G-328
Terex-Demag	G-200
XCMG	S-800
Zoomlion	S-8239

At Conexpo the big mobile crane producers are exhibiting in the Gold Lot with all four major manufacturers having impressive stands and showing a lot of product. Two Chinese manufacturers are also present, reflecting the export aspirations of crane producers in what is the world's largest crane market.

Starting at the massive **Terex** stand, you will find the **Demag AC100/4** which has recently started to ship. This will be the first opportunity for most US buyers to see this 100 tonne, four axle crane which was unveiled last year at Bauma. The maximum tip height is 254ft (77m) made up with a 165ft (50m) main boom and 89ft (27m) extension.

Moving towards the centre of the Gold Lot, stop off at the **Link Belt** stand. With most of its sales in North America, this is an important



show for the manufacturer, although it is also looking to promote its products further afield with its sights set on Europe. Link Belt is expected to make a big, surprise splash with two exciting new telescopic cranes. Ask for full details on the stand. Also take a look at its 220 tonne, five axle ATC-350 All Terrain crane with a 68 metre main boom and its 70 tonne HTC 8675 Series II truck crane, which features a longer reach and improved lift capacities.

Head towards the back corner of the Gold Lot and the **Liebherr** stand. Among the 27 products from its wide product range are three mobile cranes. Liebherr is playing its cards very close to its chest so any new products will only be revealed at the show. There will be at

least one wheeled telescopic on the stand, the 50 ton/45 tonne LTF1045 truck crane mounted on a commercial chassis with 115ft (35m) main boom and 32ft (9.5m) jib.

Next stop is the **Manitowoc** stand where all of its crane brands and support divisions are represented. Twelve cranes will be on display including seven new product launches. In addition to cranes there are areas dedicated to customer support and financing as well as a training simulator where visitors are encouraged to test their crane operating skills.

Two 'new' All Terrains are on show, the five axle 225 ton/170 tonne **Grove** GMK5225 (GMK 5170 outside the US) and the 115 ton/100 tonne GMK 5115 (GMK 5095 outside the US).

The GMK 5225/5170 has a 211ft (64m) main boom and a 330ft (100m) maximum tip height. A Cummins engine is an option instead of the standard Mercedes unit and the crane also features Megatrak suspension, ECOS electronic control, all-wheel steer and Twin Lock boom-pinning.

The smaller 100 tonne capacity GMK 5095 features a 198ft (60m) main boom with a maximum tip height of 274ft (83m) available with the hydraulic luffing bi-fold swingaway that includes an 11ft (3.3m) heavy-duty jib for more demanding lift duties.

Grove is also launching two new



Grove GMK 5225/5170

truck cranes, the 35 tonne TM500E-2 (which replaces the TM500E) on a commercial chassis with a maximum tip height of 154ft (47m). The crane's chassis is built to Grove's specifications and features a sprung front axle with air suspension on the rear which gives an improved ride at speeds up to 65 mph. The 100 tonne TMS9000E (replaces the TMS900E), features a five-section,



Liebherr LTF1045

full-power boom with Grove's Megaform profile with Twin-Lock boom-pinning technology.

The TMS9000E includes new chassis and superstructure cabs, new boom support and counterweight designs and improved accessibility for service and maintenance. Maximum main boom length is 142ft (43m) and 238ft (72m) maximum tip height. The superstructure cab tilts 20

degrees for increased operator visibility.

Continuing to the front corner of the Gold Lot the next stop is the **Tadano** America stand. Among its 11 cranes on display are nine that are new to North America, and five that are brand new world exclusives. Take a closer look at the four All Terrains, all of the G for Global models, including the new three axle 55 ton/50 tonne ATF50G-3 with its 131ft (40m) main boom and 184ft (56m) maximum tip height and the four axle 110 ton/90 tonne ATF90G-4 with its 168ft (51m) maximum tip height. Also on display are the four axle ATF65G-4 and five axle ATF220G-5. Two new truck cranes make an appearance, the GS-300XL and GS-900XL.

Cross the road now to the Silver Lot-3 where you will find the Chinese manufacturer **XCMG** which will be showing two truck cranes, a 37 ton 30K and a 75 ton 60K. Both will be available for test drives in Las Vegas immediately after the show. Fellow Chinese producer, **Zoomlion** has not yet confirmed if it will show any new Zoomlion products on its stand or if cranes will appear on its distributors stand- **Lewis Equipment** - located in the Blue Lot.



Tadano ATF90G-4

El Conexpo expondrán los fabricantes de las grandes grúas móviles en el área Gold con cuatro fabricantes con stands impresionantes y muchos productos. Dos fabricantes chinos están presentes también, reflejando sus aspiraciones de exportación de los fabricantes de grúas en lo que es el Mercado más grande de grúas.

Comenzando en el gran stand de **Terex** encontrará la grúa **Demag AC100/4** que ha comenzado a embarcarse recientemente. Esta será la primera oportunidad de muchos comparadores estadounidenses de ver esta grúa de 100 t, cuatro ejes, que fue lanzada por primera vez en Bauma. La máxima altura de elevación son 254ft (77m) alcanzados con una pluma principal de 165ft (50m) y extensión de 89ft (27m).



Link Belt Cab

Moviéndose hacia el centro del área Gold, parese en el stand de **Link Belt**. Con la mayoría de sus ventas en norteamérica, esta es una feria importante para el fabricante, aunque está buscando promocionar sus productos fuera de EE.UU. y ha puesto sus miras en Europa. Link Belt espera crear una gran espectación con dos grúas nuevas telescópicas. Pregunte por más detalles en el stand. Echele un vistazo a su modelo de grúa sobre camión ATC-350 Series II de cinco ejes y 220 tonne, con 68 m de pluma principal y su grúa sobre camión de 70 tonne HTC 8675 Series II, que ofrece un mayor alcance y capacidades mejoradas.

Dirjase a la esquina del área Gold en el stand de **Liebherr**, con 27 productos de su amplia gama de productos y tres grúas móviles. Liebherr está jugando sus cartas muy cerca del pecho por lo que solo revelará las novedades en la feria.

Habrà por lo menos una grúa telescópica montada sobre camión en el stand, la LTF1045 montada en chasis comercial con 115ft (35m) de pluma principal y 32ft (9.5m) de plumín.

La siguiente parada es el stand de **Manitowoc** donde encontrará



Terex Demag AC100/4

todas sus marcas de grúas y las divisiones de apoyo al producto representados. Se expondrán doce grúas incluyendo siete nuevos productos. Además de las grúas existen áreas dedicadas al apoyo al cliente y financiación, así como un simulador de formación donde los visitantes podrán demostrar sus habilidades.

commercial con altura maxima de 154ft (47m). El chasis de la grúa está construido con las especificaciones de Grove con eje frontal y con susensión por aire en la parte trasera que ofrece mayor rendimiento a velocidades hasta 65 mph. La TMS9000E (reemplaza a la TMS900E) de 100 tonne, tiene una pluma de cinco secciones, con el Megaform

Dentro de las 11 grúas que exponen, 9 de ellas son nuevas para el mercado norteamericano y cinco son novedad a nivel mundial. Echele un vistazo a las cuatro todo terreno, todas G de Modelos Globales, incluyendo la nueva grúa de tres ejes de 55ton/50tonne ATF50G-3 con sus 131ft (40m) de pluma principal y altura máxima de 184ft (56m) y la grúa de cuatro ejes de 110 ton/90 tonne, la ATF90G-4 con sus 168ft (51m) de pluma principal y 234ft (71m) de altura máxima. También estarán expuestas la grúa de 4 ejes ATF65G-4 y la de 5 ejes ATF220G-5. Dos nuevas grúas sobre camión, la GS-300XL y GS-900XL.

Cruce la calle ahora hacia el área Silver - 3, donde encontrará al fabricante chino **XCMG** que expondrá dos grúas sobre camión, el modelo 30K de 37 ton y el modelo 60K de 75 ton. Ambos modelos estarán listos para ser probados en Las Vegas inmediatamente después de la feria. Otro fabricante chino, **Zoomlion** todavía no ha confirmado si expondrá algún Nuevo producto Zoomlion o si las grúas estarán en los stands de sus distribuidores - **Lewis Equipment** - localizado en el área Blue.



The new Tadano TM35100 - boom truck or truck crane?

Habrà dos nuevas todo terreno, la tonne **Grove** GMK5225 (GMK 5170 fuera de EE.UU.), una cinco ejes con capacidad de 225 ton/170 tonne y la tonne GMK 5115 (GMK 5095 fuera de EE.UU.), con 115ton/100 tonne.

La GMK 5225/5170 tiene una pluma principal de 211ft (64m) y una altura maxima de 330ft (100m). Se ofrece como opción un motor Cummins en vez de el motor Mercedes de serie. Incorpora suspensión Megatrak, control electrónico ECOS, giro en todas las ruedas.

La GMK 5095, de 100 tonne de capacidad tiene una pluma principal de 198ft (60m) con altura máxima de 274ft (83m) disponible con plumín hidráulico que incluye plumín de 11ft (3.3m) para trabajos pesados.

Grove lanzará dos nuevas grúas sobre camión, la TM500E-2 (que reemplaza a la TM500E), de 35 tonne montado en chasis

de Grove con tecnología Twin-Lock. La TMS9000E incluye un Nuevo chasis y cabina de la superestructura, Nuevo soporte de pluma y diseño del contrapeso y accesibilidad mejorada al servicio y mantenimiento. La longitud maxima de pluma son 142ft (43m) y 238ft (72m) de altura maxima. La cabinade la superestructura se inclina 20 grados para obtener una mayor visibilidad del operario.

Continuando hacia la esquina frontal del área Gold la próxima parada es el stand de **Tadano America**.



Grove TM500E

Subscribe to **cranes** & **access**

The only way to
guarantee
that you
receive
every
issue.

Vertikal
.net

Subscribe online at www.vertikal.net



Subscription Application Form

Please complete this form and either fax back on
+44 (0) 1295 768223 or +49 (0) 7618 866814 or
post to The Vertikal Press, PO Box 6998,
Brackley, NN13 5WY, UK. Tel: +44 (0)8707 740436

Name _____

Company _____

Job Title _____

Telephone _____

Address _____

Country _____

Telefax _____

Email _____

Please start my one year subscription to Cranes & Access at the rate of:

- £40.00/€60 (UK and Irish addresses only)
- €75.00 (Rest of Europe)
- \$110.00 / £60.00 (Other regions)
- I enclose a cheque made payable to The Vertikal Press
- Please invoice me
- I enclose an international money order

MAT & TIMBER SERVICES



CRANE MATS

OUTRIGGER MATS

**TEMPORARY
ACCESS ROADS**

RAMPS

For all types of
cranes under any
application -
Nationwide and
Overseas



TEL: +44 (0) 1264 811005
FAX: +44 (0) 1264 810600

e-mail: info@sarumhardwood.co.uk

web site: www.sarumhardwood.co.uk

Manufacturer • Fabricante	Stand
Rough Terrain Cranes • Grúas para terrenos accidentados	
Bendini	Terex-G-200
Link Belt	G-240
Grove	G-353
Tadano	G-328
Terex	G-200
Industrial Cranes • Grúas industriales	
Broderson	G-127
Grove	G-353
Lift Systems	B-971
Shuttlelift	G-363
Spider Cranes. Grúas de araña:	
Jekko	RL-41030
Maeda	G-277
Unic	RL-44013

Those looking for a Rough Terrain crane have it easy at this year's show with all four manufacturers situated in the Gold Lot. Starting on the Terex stand, the crane not to miss is the new 120 ton RT1120 a product of international co-operation. The boom and upper comes from Terex Demag, while the chassis from Terex-Waverly has P&H/Lorain genes. The five section boom gives a basic hook height of 155ft to which you can add a 30 to 56ft bi-fold extension plus up to two additional 26ft jib-inserts for a maximum of 271ft. Powered by a 300hp Cummins engine, the unit has disc brakes on all four wheels.

Across the aisle is Shuttlelift, now part of the Manitowoc crane group. It has the new nine ton 3339 on display, featuring a full-power 33ft three-section boom and 360 degree continuous boom rotation.

Almost next door is Tadano with a large stand to cope with the number of new models and machines making



Aquellos que busquen grúas para terrenos abruptos pueden empezar por Terex, con su grúa de 120 ton RT1120. La pluma es de Terex Demag, mientras que el chasis de Terex-Waverly tiene genes P&H/Lorain. La pluma de 5 secciones ofrece una altura de gancho de 155ft a la que le puedes añadir extensión de 30 a 56ft más dos plumines adicionales de 26ft para alcanzar 271ft. Equipada con motor de 300 hp Cummins y discos de freno en las cuatro ruedas.

Haciendo su debut en América, en el stand de Manitowoc estará la Grove RT540E, una grúa para terrenos abruptos de 40 ton con pluma de cuatro secciones de 102ft. Mire también la Grove YardBoss YB4409-2. Con pluma y configuración de plumín de 51ft. Puede elevar 9 ton a 360°.

Cruzando el pasillo está Shuttlelift, ahora parte del grupo Manitowoc, y tendrá la 3339 de 9 ton expuesta, con pluma de tres secciones de 33 ft.

Casi al lado, Tadano expondrá por primera vez en América nuevos productos. Vea dos grúas, una de 15 ton, la GR-150XL y la de 80 ton GR-800XL.

No debe perderse el stand de Link Belt que promete desvelar nuevos modelos pero no ha dado mucha información al respecto. Seguro que tendrán expuestos varios modelos de grúas para terrenos abruptos.

La última parada en el área Gold es el especialista en grúas pick&carry, Broderson.

Terex RT1120



their North American debut.

Two Rough Terrain cranes will be on display - the 15 ton capacity GR-150XL and the 80 ton GR-800XL.

Another 'must see' is the Link Belt stand which is promising to unveil new models but has been very tight lipped about what exactly. You can be sure that it will have a number of RT units on display.

Last stop in the Gold Lot is industrial pick and carry crane specialist, Broderson.

Then its off to the Blue Lot to see Lift Systems which has a new 30 ton Mobilift pick and carry crane on show. Maximum capacity is at 6ft radius while it can take 10 tons to just over 20ft. The company also has a new 100 ton jacking system

Spider cranes

There are a number of small crawler mounted spider cranes on show this year, Maeda is located at the back of the Gold Lot and will show three spider models - the MC285C, MC305C and MC405C - and its good-looking six ton LC785 mini crane. Up and coming Jekko with a five model line up and Furukawa-Unic are both located in the Riviera Hall next to the Gold Lot.

Tadano GR 150XL-1



Ahora vaya al área Blue para ver el stand de Lift Systems que cuenta con una nueva grúa de 30 ton pick and carry Mobilift. Su capacidad máxima se da a un radio de 6 ft mientras puede llevar 10 tons a 20ft. La empresa tiene un nuevo sistema de gatos de 100 ton.

Grúas de araña

Existen varios fabricantes de grúas tipo araña este año exponiendo, Maeda está al final del área Gold y expondrá tres modelos de araña - el MC285C, MC305C y MC405C y su mini grúa de seis ton LC785. Jekko dispone de cinco modelos dentro de su gama y Furukawa-Unic y ambos están situados en el Hall Riviera próximos al área Gold.

Grove RT540E

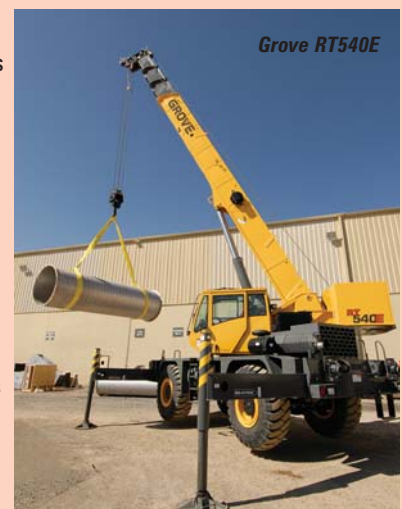



Manitowoc: Performing near you

The 200 t (220 US t) Model 14000 joins Manitowoc's celebrated line of lattice-boom crawler cranes, offering an 86 m (282 ft) main boom and 113.7 m (373 ft) luffing jib. The Model 14000 features the exclusive EPIC[®] with Can-Bus control system enhancing the performance of all crane functions. Crane setup is optimized using FACT[™] connection technology to reduce assembly times.

For more information about the Manitowoc Model 14000, go to: www.mcgads.com/1185.



Manufacturer • Fabricante	Stand
Fushun	G-156
Jekko	RL-41030
Kobelco	G-320
Lampson	B-952
Lewis Equipment	B-950
Liebherr	G-374
Link Belt	G-240
MAIT Spa	S-734
Maeda	G-277
Manitowoc	G-353
Sany	S-634
Terex	G-200
Tes Car	S-19135
Unic	RL-44013
XCMG	S-800
Xuzhou-Intensus	S-800

North America is the traditional home of the crawler crane and this year's show has been blessed with an impressive turnout with most of the major crawler exhibitors situated in the Gold Lot.

Starting at the back of the Gold Lot is mini crawler producer **Maeda**. Next stop is **Liebherr** which is showing its LTR 1100 telescopic crane on a crawler chassis, with a maximum lifting capacity of 110 tons/100 tonne and 172ft/(52m) telescopic boom. The unit combines the advantages of a telescopic crane - shorter set-up times, easier transportation and the variability of the boom and jib layout to suit each lift with the compact dimensions and mobility of a crawler. Liebherr's extensive lattice boom range is represented by its 300 tonne LR 1300 which has a maximum boom jib combination of 567ft (172m).

Moving around the perimeter of the Gold Lot you will see the all hydraulic **Manitowoc** Model 14000. In spite of its 2006 launch, this is its US show debut. The 200 tonner



Liebherr LTR 1100

features a main boom of up to 292ft which extends to 363ft with luffing jib. Continuing in a clockwise direction, you should be able to see the boom of **Kobelco's** largest crawler crane available outside of Japan, the 600 ton/550 tonne SL6000, which is making its North American debut. The company will also have its CK1000-III (100 US ton) and CK2500-II (250 US ton) capacity machines on the stand.

Moving across the aisle to the **Terex** stand and

you will see the new **Demag** HC230 crawler crane. With a 230 ton lift capacity at 14ft - and at 16ft when fitted with a 92 HI boom/offset tip - the unit has a 390ft maximum boom length with boom extension. It also features a load-sensing hydraulic system for smoother and more precise work.



Terex HC230

Now head towards the centre of the Gold Lot and the **Link Belt** stand. The company has at least three crawler cranes including the debut of its largest lattice crawler ever along with an upgraded 138 HSL 80 ton (72.6 tonne) crawler with better capacities and easier assembly and transportability and a true replacement for its aging 230 ton (209 tonne) 298 HSL crawler.

Almost opposite is **Fushun**, China's largest specialised manufacturer of crawler cranes. Cross to the Silver Lot 1 to check out the **Sany** stand which might include a crawler crane, its range is now topped out by a 900 tonne capacity model launched in January. Silver Lot has **MAIT** and its foundation cranes and then onto another Chinese manufacturer, **XCMG** which also may have a crawler crane amongst its many other product lines. Finally over in the Blue Lot Lampson, the producer of specialist mega crawler cranes has a small booth.

Norteamérica es el Mercado tradicional de las grúas sobre orugas y este año la mayoría de los expositores de grúas sobre orugas estarán ubicados en el área Gold.

Comenzando por el final del area Gold se encuentra el fabricante de mini grúas sobre orugas **Maeda**. La siguiente parada es **Liebherr**, que expone su grúa telescópica sobre orugas LTR 1100, con una capacidad máxima de 110 tons/100 tonne y pluma telescópica de 172ft/(52m), la unidad combina las ventajas de una grúa telescópica - menor tiempo de montaje, fácil transporte y variedad de deslague de pluma

y plumín para adaptarse a cada elevación con las dimensiones compactas y movilidad de una grúa sobre orugas. La gama extensa de Liebherr de grúas de celosía estará representada por su modelo de 300 tonne LR 1300 que ofrece una combinación de pluma plumín de 172m. También habrá oportunidad de ver su impresionante grúa de 650 tonne LR1600-2, así que para verla bien tendrá que alejarse un poco.

Movindose por el perímetro del área Gold se encontrará con el modelo 14000 de **Manitowoc**, un equipo totalmente hidráulico. Aunque se presentó en 2006, este es su primer debut en EE.UU. Este equipo de 200 tonne tiene una pluma de hasta 292ft que se extiende hasta 363ft con plumín. Continuando en esa dirección podrá ver la pluma de de **Kobelco** de la mayor grúa sobre orugas que existe fuera de Japón, la SL6000, una máquina de 600ton/550 tonne, que hace su debut en EE.UU. La empresa también tendrá su modelo CK1000-III (100 US ton) y CK2500-II (250 US ton).

En el stand de **Terex** verá la nueva **Demag** HC230 sobre orugas. Con una capacidad de elevación de 230 a 14ft - y a 16ft cuando está equipada con una pluma 92 HI boom - la unidad tiene una longitud máxima de pluma de 390ft con extensión de pluma. Incorpora un sistema hidráulico de sensor de carga para un trabajo más suave y preciso.

Ahora diríjase hacia el centro del área Gold en el stand de **Link Belt**. La empresa tendrá al menos tres grúas sobre orugas incluyendo el debut de su mayor grúa de celosía junto con una mejorada 138 HSL 80 ton (72.6 tonne) grúa de orugas con mejores capacidades y más fácil montaje y transporte y un verdadero reemplazo de su grúa de 230 ton (209 tonne) 298 HSL.

Casi en el otro lado se encuentra **Fushun**, el mayor especialista fabricante de grúas de celosía.

Vaya al área Silver 1 para ver el stand de **Sany** que puede que exonga una grúa de celosía, su gama llega hasta un modelo de 900 tonne. En el Silver Lot 2 está **MAIT** y sus grúas, y ahora hacia otro fabricante chino de grúas, **XCMG** quién puede que también tenga una sobre orugas además de sus otros productos. Finalmente en el área Blue verá **Lampson**, el fabricante especialista en grandes grúas de celosía.



Kobelco SL6000



Link Belt



Manitowoc 14000

WOLFFKRAN

High flyer

Ready for new challenges



Visit us:
Central 1-2 Indoor
Stand C-4033-6

WORLD PREMIERE | WOLFF 355 B | THE NEW GENERATION | GLOBALLY PATENTED

Cranesational technology from WOLFFKRAN is in use throughout the world: from Denver to Dubai, from Australia to Abu Dhabi. Whatever you want to build, as far as construction site efficiency is concerned, WOLFFKRAN will take you into the lead.

Visit us at the ConExpo Show: we look forward to seeing you!

www.wolffkran.com Der Leitwolf. *The leader of the pack.*



Manufacturer • Fabricante	Stand
Comedil Terex	G-200
Jaso	S-553
Lewis Equipment	B-950
Linden Comansa	G-380
Liebherr	G-374
RD Lift SRL	RL-44013
Peiner Terex	G-200
Potain	G-353
Sun Crane	B-950
Terex	G-200
Wolffkran	C-4033-6
Zoomlion	S-8239

There are many more tower crane manufacturers at Conexpo this year, reflecting the tremendous growth in the sector due to the global buoyancy of the world's construction industry.

The far side of the Gold Lot is the place to start with Spanish company **Linden Comansa**. Two flat top cranes - the 21LC550 and the 5LC5211 - from its 500 and 2100 series machines will be on show. Both are easily assembled in the air and because component parts are light, a smaller erection crane can be used.

Directly opposite Comansa is the mighty **Liebherr** which is showing two larger tower cranes - the 355 HC-L 16/32 Litronic luffer and the 550 EC-H 20 Litronic saddle jib model. New features on the smaller 355

tonne/metre class machine include the PLC control system which allows horizontal movement of the load as the luffing jib is moved, a bolted-on climbing console and rapid re-reeving from a single to a double rope run.

The larger 550 EC-H is shown in the 20 tonne version but is also available in 12 or 40 tonne. When the Litronic version is chosen, loads up to 9,000lbs (4,000kg) at maximum radius can be lifted.

The stand crane has a hook height of almost 287ft (87m) and an undercarriage with track width of 33ft (10m).

Moving to the **Manitowoc** stand, **Potain** is showing two new models - the self erecting Igo T85 and the MDT 268 topless tower crane.

The Igo T85 is a bigger brother to the Igo T70 launched last year and similarly features a telescopic lattice tower. It has a six tonne maximum capacity and 148ft (45m) jib which can lift 2,750lbs (1,250kg) at its tip. The MDT 268, the largest in the MDT range, offers a 213ft (65m) jib with 5,500lbs (2,500kg) tip capacity.

Continuing clockwise around the Gold Lot, **Terex** is showing its new range of Flat Top **Comedil** cranes the CTT series. Positioned between the City and the larger cranes, the range was



Liebherr ECH range

created with the introduction of the 10 and 12 tonne CTT 231 and will be expanded with the introduction of new models.

Maximum jib length of the CTT 231 is 230ft (70m) with 4,500lbs (2,100kgs) tip capacity.

Cross now to the Silver lot and next door to **Vertikal** is Spanish tower crane manufacturer **Jaso** with an information booth. Continue to the central hall and at the front you will find German manufacturer **Wolffkran** with a booth promoting its new 355B luffing jib crane,

first seen at Bauma, and looking to expand its presence in the North American market.

Finally in the Blue Lot, **Lewis Equipment** will be showing the **SunCrane** tower cranes.



Terex-Comedil

Potain MDT



Hay muchos fabricantes de grúas torre este año en la feria, reflejando el tremendo crecimiento en el sector debido al crecimiento boyante de la industria de la construcción.

El lugar para empezar es el lado más alejado del área Gold, comenzando con el fabricante español **Linden Comansa**. Dos grúas flat top - la 21LC550 y la 5LC5211 - de su serie de máquinas 500 y 2100. Ambas son de fácil montaje en el aire porque sus componentes son ligeros.

Directamente enfrente se encuentra **Liebherr** que expondrá dos grandes grúas torre - la 355 HC-L 16/32 Litronic y la 550 EC-H 20 Litronic. Nuevas características en la máquina más pequeña de 355 tonne/metre incluye sistema de control PLC que permite movimiento horizontal de la carga a medida que se mueve el plumín.

La gran 550 EC-H se expondrá en versión 20 tonne pero está disponible en 12 ó 40 tonne. Cuando se elige la versión Litronic, se pueden elevar cargas hasta 9,000lbs (4,000kg) a un radio máximo. La grúa en el stand tiene una altura bajo gancho de casi 287ft (87m) y un undercarriage de 33ft (10m).

En el stand de **Manitowoc**, **Potain** expone dos nuevos modelos, la auto montante Igo T85 y la MDT 268, una grúa torre topless.

La Igo T85 es la hermana mayor de la Igo T70 lanzada el año pasado.

Tiene una capacidad de 6 tonne y plumín de 148ft (45m) que puede elevar 2,750lbs (1,250kg) en punta. La MDT 268, la más grande de la gama MDT, ofrece plumín de 213ft (65m) con 5,500lbs (2,500kg) de capacidad.

Continuando en el sentido contrario a las agujas del reloj en el área Gold, Terex expondrá su nueva gama de grúas Flat Top **Comedil**, la serie CTT series. Posicionada entre las grúas City y las grandes grúas, la gama fue creada con la introducción de la CTT 231 de 10 y 12 tonne CTT 231 y se expandirá con el lanzamiento de nuevos modelos. La longitud máxima del plumín es de 230ft (70m) con capacidad de 4,500lbs (2,100kgs).

Cruce ahora al área Silver y junto al stand de **Vertikal** se encuentra el stand del fabricante español **Jaso**, con un stand informativo.

Continúe al hall central donde encontrará al fabricante alemán **Wolffkran** con un stand promocionando su grúa torre de plumín 355B, vista por primera vez en Bauma, y quiere expandir su presencia en norteamérica.

Finalmente en el área Blue, **Lewis Equipment** expondrá las grúas torre **SunCrane**.



Only dummies don't wear harnesses on booms

Why do some aerial work platform operators seem to be so dumb, particularly those who don't wear harnesses on boom type platforms? Don't they recognize the danger they are putting themselves into? Don't they realize that they could be catapulted out of the platform if something unexpected happened?

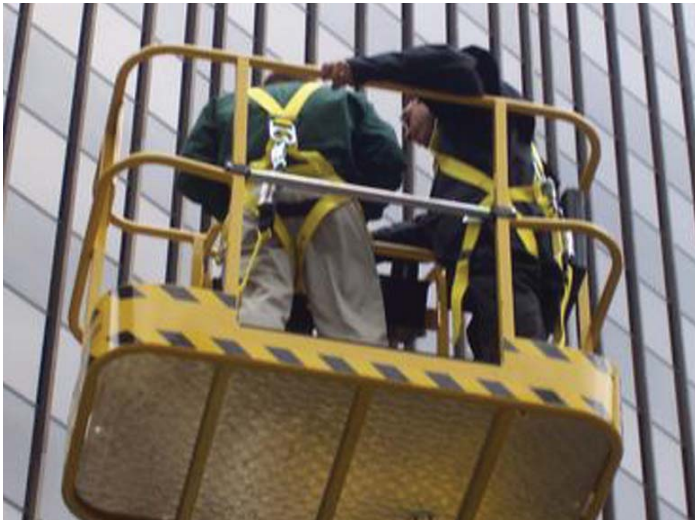

AWPT is running dramatic demonstrations on the dangers of not wearing a harness in boom type platforms, daily at 10:00am, 12:00 noon, 1:00pm, 2:00pm and 4:00pm on Booth SZ1000.

It only takes a moment and you don't need to be at any great height. The ground beneath the machine could give way, or the machine could be driven into a pothole or over a ground level obstacle, causing the platform to jolt

violently. Or a vehicle, crane or object could hit the machine. If one of these events occurs, the jarring forces transferred through the boom to the platform are so strong that two grown men not wearing harnesses can be easily catapulted out of the platform, often with deadly results. Wearing a harness and short lanyard saves lives. Although aerial

platforms are basically a safe way of working at height, harnesses are a way of guarding against this known risk and make working at height even safer. It is an OSHA and ANSI requirement to wear a harness while occupying a boom lift, so it isn't optional for the operator to begin with. Nonetheless, it is a daily occurrence to see operators in boom lifts without a harness on. So if wearing harnesses makes operating boom type platforms safer, why aren't boom operators wearing them? One reason is that some people have not been properly trained to use aerial platforms correctly.

These machines are deceptively easy to use - push this lever and it goes up, push that one and it goes down. As a consequence, too often only the basic familiarization of the machine is provided, incorrectly accepting this as training.

Then, as the saying goes: "A little knowledge can be a dangerous

thing." A specialized piece of equipment in the hands of an unqualified person can be dangerous to both the operator and the people around him or her.

An untrained operator does not know how to perform a pre-start inspection before each use. He does not know that he must perform a site inspection to check the ground conditions for items like drop-offs, holes, and debris in the area. He does not know how to use outriggers, stabilizers or spreader pads correctly. An untrained operator may not know that there could be blind spots during operation that must be checked. And he does not know that he should wear a full body harness with a short restraint lanyard attached to a suitable anchor point. These are some of the vital things that can help prevent accidents or save lives if accidents do occur.

Another reason that some people don't wear harnesses when they should is false bravado. "I don't need a harness for a quick job; I've used these machines lots of times and I've never needed a harness"; or "I'm not going to climb on the guard rails or lean out, so I don't need one" is often heard on sites. These people think that they are being fearless by not harnessing up and clipping on. What they don't realise is that they are placing themselves at an incredible risk and that one sudden unexpected movement of the boom could end their lives. And all this could have been prevented if they had simply buckled up and clipped on.

Harnesses with restraint lanyards set as short as possible should be worn on boom type platforms to stop the operator from getting into a position where he can fall. It is also important to check the lanyard for damage before each use. Lanyard damage, especially abrasion, can seriously compromise performance. Ideally, each operator should be responsible for his own harness. Lanyards must always be attached to a manufacturer provided attachment point and not be attached to anything outside the basket of the boom. In certain rare circumstances, the wearing of harnesses in a boom

type platform may not be the safest option. For example, in low-level work over water where there is an associated risk of drowning if the aerial device were to tip over

into the water, the general advice to wear harnesses in boom type platforms may be overruled. The most important thing to do is to perform a job-specific risk assessment before starting any work.

"Only dummies don't wear harnesses on booms" will occur literally during IPAF's live demonstrations at the CONEXPO Safety Zone (Booth SZ1000). IPAF will show the impact on a manikin not wearing a harness during operation of a boom lift. You will see with your own eyes and leave saying to yourself - "Don't be a dummy - Click-It".

Increased aerial platform safety is the goal of the not-for profit International Powered Access Federation (IPAF) and its North American subsidiary, Aerial Work Platform Training (AWPT). Promoting the use of harnesses in boom type platforms is part of that goal. In response to concerns from industry and safety authorities, IPAF developed simple guidance notes on when and how to use harnesses. This policy is outlined in technical guidance note H1 (available at the Publications sections of www.ipaf.org and www.awpt.org). Last year, rental members of IPAF were so frustrated with the number of unnecessary deaths caused by people not wearing harnesses in boom type platforms that they got together to take action. The Clunk Click campaign was launched. This initiative is centered around a brightly coloured sticker that is placed in the platform to remind people to wear a harness in a boom lift. Thousands of posters and stickers have been printed in different languages and distributed through rental companies, safety authorities and equipment manufacturers that support the program. The campaign has reached countries including Germany, Italy, the Netherlands, Switzerland and the US, with the North American version, Click It!

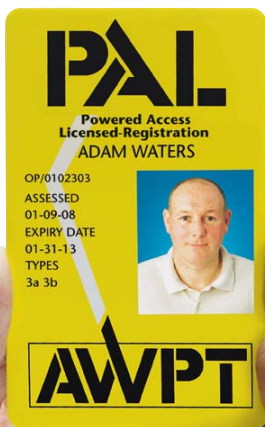

Sólo unos tontos maniqués no utilizan arnés en plataformas aéreas de brazo

¿Por qué algunos operadores de las plataformas aéreas de trabajo parecen ser tan tontos, en particular aquellos que no utilizan el arnés en plataformas aéreas de brazo? ¿No reconocen el peligro al que se están exponiendo? ¿No se dan cuenta de que podrían ser catapultados fuera de la plataforma al chocar con algo inesperado?



Wearing a harness is easy and is the mark of professional trained platform operators

El efecto catapulta sucede en un momento y puede pasar tanto cuando te encuentras en altura como cuando estás con el brazo recogido. Un deslizamiento del suelo, un bache o un obstáculo sobre el nivel del suelo, puede sacudir violentamente la plataforma. También un choque con un vehículo, una grúa o un objeto. Si uno de estos eventos ocurre, las fuerzas transferidas a través del brazo a la plataforma son tan fuertes que dos hombres adultos que no lleven el arnés podrían ser fácilmente catapultados fuera de la plataforma, a menudo con resultados mortales. El uso de un arnés podría salvar la vida en todos casos. Aunque las plataformas aéreas son básicamente una forma segura de trabajar en altura, llevar un arnés es una forma de protección

añadida contra este riesgo demostrado y hace que el trabajo en altura sea incluso más seguro.

Llevar un arnés en plataformas aéreas de brazo es requisito OSHA y ANSI, con lo cual no se trata de una decisión facultativa. No obstante, todos los días seguimos viendo operadores de plataformas aéreas de brazo que no llevan arnés. Por lo tanto, si el uso del arnés hace el trabajo más seguro, ¿por qué los operadores siguen trabajando sin arnés? Una de las razones es que algunas personas no han sido adecuadamente formadas para utilizar correctamente las plataformas aéreas. Estas máquinas son engañosamente fáciles de manejar - "pulsas este botón para subir y este otro para bajar". En consecuencia, demasiadas veces se proporciona in situ una sesión de familiarización sobre la máquina y se considera como formación. Pero como bien sabemos, un conocimiento superficial puede ser algo muy peligroso. Un equipo de trabajo tan especial en las manos de una persona sin los adecuados conocimientos, puede ser peligroso tanto para el operador como para las personas alrededor.

Un operador que no ha recibido formación no tiene los conocimientos necesarios para realizar una inspección de la máquina antes del uso, no sabe realizar una inspección in situ para verificar las condiciones del terreno, detectar baches, agujeros, desniveles, escalones en el área donde va a efectuar el trabajo. No sabrá cómo usar los estabilizadores, o como posicionar de forma eficaz las placas de apoyo para una repartición adecuada de la carga. Un operador inexperto puede no saber que podría haber ángulos muertos durante la operación que deben ser revisados. Tampoco sabrá que debe usar un arnés de cuerpo completo con una eslinga correctamente

AWPT
Technical Guidance
Personal Fall Protection in Aerial Work Platforms
 • Boom-Supported Work Platforms (Boom Lifts) ANSI A92.5 and Vehicle-Mounted and Towable Work Platforms ANSI A92.2

IPAF
Click It!
 The ANSI standard for Boom-Supported Elevating Work Platforms (A92.5) and the Canadian Standard for Boom-Supported Elevating Work Platforms (CSA B354) require that fall protection be provided in the platform near fall protection devices at all times. The OSHA regulation for aerial lifts (29 CFR 1926.1013) requires the use of a full body harness when working from an aerial work platform. The full body harness should be attached, via a lanyard, to a lanyard anchorage point.

There are no current requirements by ANSI, CSA or OSHA requiring manufacturers covered under the ANSI standards A92.5 and A92.2 and the CSA standard B354.2.

This guidance note was issued by Aerial Work Platform Training Inc. (AWPT), a subsidiary of the International Powered Access Federation (IPAF) in June 2007. It was produced in association with the Scaffold Industry Association which fully endorses its recommendations.

AWPT is the North American subsidiary of IPAF, the organization that promotes the safe and effective use of powered access equipment worldwide. AWPT training complies with OSHA requirements and is based on IPAF training which is certified in conformity to the international standard ISO 18001. AWPT offers the IPAF Certified Powered Access Lifting and Platforming to people who successfully complete a training course on powered access equipment at an approved training centre (more than 50000 IPAF Centres are reported each year through over 200 approved training centres worldwide). The IPAF Centres are required by the ISA as proof of training in the use of aerial work platforms, and similar work platforms.

www.awpt.org
 For information about AWPT's full range of training programs for all kinds of AWPs visit www.awpt.org

AWPT
 AWPT Training complies with OSHA requirements.
 AWPT Inc, PO Box 207, Bensenville, PA 17520-0207, USA.
 Tel: +1 717 762 1911 Fax: +1 717 762 9055
 mail@awpt.org www.awpt.org

A subsidiary of IPAF
 International Powered Access Federation
 Bridge End Business Park, Millthorpe LAD 79N, UK.
 Tel: +44 (0)15195 62444 Fax: +44 (0)15195 64666
 info@ipaf.org www.ipaf.org

IPAF
 The world authority in powered access

Download a copy of H1, the industry standard guidance on when to wear a harness, from www.awpt.org

ajustada enganchada a punto de anclaje adecuado cuando se trabaja en plataformas aéreas de brazo. Estas son sólo algunas de un largo listado de cosas que podrían evitar graves accidentes o salvar vidas en caso que se produzca el accidente.

Otra razón por la que algunas personas no utilizan el arnés cuando deberían, es que trabajar sin él lo consideran un acto de valentía. En las obras escuchamos muy a menudo afirmaciones como estas: "No necesito un arnés para un trabajo de nada; he utilizado estas máquinas muchas veces y nunca he necesitado un arnés", o también "ni voy a subirme a la barandillas ni voy a asomarme, así que no necesito un arnés". El trabajar sin "ataduras" parece que les hace más valientes y bravos. Lo que no se da cuenta es que se están exponiendo innecesariamente a un riesgo increíble: un movimiento inesperado del brazo de la plataforma podría acabar con sus vidas. Y todo esto se podría haber evitado si se hubieran enganchado debidamente.

Es evidente que el operador de plataformas aéreas de brazo tiene que llevar un arnés con una eslinga lo más ajustada posible para evitar que se encuentre en una posición con riesgo de caída. También es importante comprobar, antes de cada uso, que la eslinga y el arnés no presenten daños. Daños en la eslinga, en especial la abrasión, pueden comprometer seriamente su rendimiento. Idealmente, cada operador debería disponer de su propio arnés del cual él es el responsable. Las eslingas deben siempre estar enganchadas en el punto de anclaje definido por el fabricante de la plataforma y no a un punto cualquiera que se encuentre fuera de la cesta. En algunas raras circunstancias, el uso de arneses en plataformas aéreas de brazo puede no ser la opción más segura. Por ejemplo, en trabajos a bajo nivel por encima del agua donde existe un riesgo de ahogamiento si el dispositivo aéreo volcara en el agua. El consejo general de llevar el arnés en plataformas aéreas de brazo en este caso no se aplicaría. Lo más importante, antes de iniciar cualquier trabajo, es llevar a cabo evaluación de riesgos específica para la tarea a realizar. La demostración práctica que "Sólo unos tontos maniqués no utilizan el arnés en plataformas aéreas de brazo" tendrá lugar en la feria Conexpo en la Zona de Seguridad IPAF (Stand SZ1000). IPAF demostrará el impacto sobre un maniquí que no



In preparation for Conexpo, AWPT has printed enough Click It! stickers for each and every boom in the nation. Help us get a Click It! sticker on every boom platform and help save lives.

leva un arnés en una plataforma aérea de brazo. Podrás ver con sus propios ojos y acabar diciéndote a ti mismo: "no seas tonto, iengánchate!"

The boom is definitely back.

View the new Snorkel range at:
CONEXPO, Booth #G-117



NEVER THINK SMALL.

Snorkel doesn't claim to be the industry giant. But if you want aerial equipment big in capabilities, big in quality and big in value, Snorkel more than measures up.

From spec'ing your equipment to building it, we take the time to do things right. So you get a better-made lift that operates easily, works hard and lasts long. A lift customized with everything you need and nothing you don't.

You also get the assurance of Snorkel's on-time delivery - a standard of service in which we lead the industry.*

For all your aerial jobs, go ahead and think big. Snorkel can handle it.

*Details on request.

Snorkel

PLATAFORMAS AUTOPROPULSADAS ■ SELF PROPELLED BOOMS

Manufacturer • Fabricante	Stand
Aichi	S-8907
Bil-Jax	S-8417
Genie/Terex	G-200
Haulotte	G-236
Hinowa	S-16200/B-962
Italmecc Manlifts	C-7107
JLG	G-170
Loeering	C-5796
Manitou	G-195
MEC	B-959
Niftylift	SZ-1000
PM/Oil & Steel	RL-43033
ReachMaster	B-962
Skyjack	B-958
Snorkel	G-117
UpRight	G-117
Worldlift	B-962



SkyJack

Self Propelled boom lifts are well represented at Conexpo this year. The number of companies seriously producing boom lifts is expanding following a number of years when the choice of supplier has been limited. As a result a number of all new boom lifts are being unveiled at the show, here is what to look out for.



Snorkel
AB46JRT

We suggest that you start at SkyJack in the middle of the Blue Lot. Some two years after it announced its re-entry into the boom lift market, the company has made a solid start to what will be a full line of rugged, simple

to own boom lifts. The stars of the stand are the new 61 and 66ft straight telescopic booms, the 66ft with jib. The new models build on the principles laid down on its 40/45ft family. Check-out the husky axle type 4x4 system, 45 degree crank angle steering and its numerous back to basics serviceability features.

Across one aisle is Reachmaster which has its range of spider type boom lifts on display, including Hinowa, Denka and Falck Schmidt - the original spider lift. The company, a division of Worldlift Industries, has established itself as the foremost expert on gaining access to high atriums. Its products pass easily through standard doors and even up escalators, before telescoping up to 50 metres.

Across the other aisle you will find the latest entrant to the boom lift market - MEC. Yes scissor-lift MEC is now into booms. The company is unveiling its all new M40T and M46T, a family of telescopic booms designed from the ground up by ex Genie and UpRight engineers. Check out the tailswing, oscillating axle, turning circle and what it refers to as its California customisation.

If you head into the Central Hall you will find Italian spider lift producer - Italmecc testing the North American market. Continue out into the South Hall where you will find Bil-Jax and it's new X series lightweight self propelled articulated booms. The new 45XA, making its debut, offers a 45ft platform height and yet weighs less than 4,500 lbs/2,000 kg. It joins the 36XT launched last year and shares its 45 percent gradeability, rapid travel speed and fast set up time. Let the team demonstrate the 30 second outrigger set up time.

A late entry from Aichi also can be found in the South Hall on the Toyota stand, where it will have its brand new 46ft straight telescopic boom on show.

Carry on past the Vertical Press stand - do say hello - and onto the Gold Lot where first stop is Snorkel/UpRight. The two brands now merged will be flying the Snorkel flag since we are in the good old US of A. This will be the first chance for many to meet the senior managers of new owners - Tanfield and learn more about the company's aggressive expansion and development plans. Across the aisle you will find the massive Terex stand and Genie will have a good selection of its booms on display and might yet surprise us with something new?



Mec is now
into booms

If you have not already seen it, focus on the Z40/23N its revolutionary 40 ft articulating boom with direct AC drive system. Unveiled a year ago it is now in full production.

Cross the other aisle now to find the Haulotte stand - a stop here is a must. Now well established as the world's third largest producer, it has a new product on display, the 86ft - HB86TJ+

(HA28TJ+) that is quite different from traditional telescopic booms, with its tight tailswing,



16.5ft/5m telescopic jib and a big platform capacity. The company also has a full selection of its telescopic and articulated boom lifts on display.

Don't overlook its smallest boom lift, the 26ft Star 26J Star 10) Mast Boom.

Now carry on towards the back of the show where you will find JLG - now owned by Oshkosh, and one of the more impressive exhibits at the show. While it is not planning to unveil any radical new products it has put a good deal of effort into refining and improving its broad product range.

You might also note a refreshingly friendly and down to earth atmosphere on the stand.

Finally a short step away is Manitou. While not exhibiting its booms here, it does have a well stocked stand and its senior managers will be very happy to talk about its access products.



HB 86 TJ+

SKYJACK'S **NEW**

SJ 61T and SJ 66T BOOMS

See them at CONEXPO. Blue Lot B-958 Gold Lot G-300



We're in the business of engineering
reliable lift solutions
by people who care.

For information call +44-1691-676235
or visit us online at www.skyjack.com

SKYJACK[™]

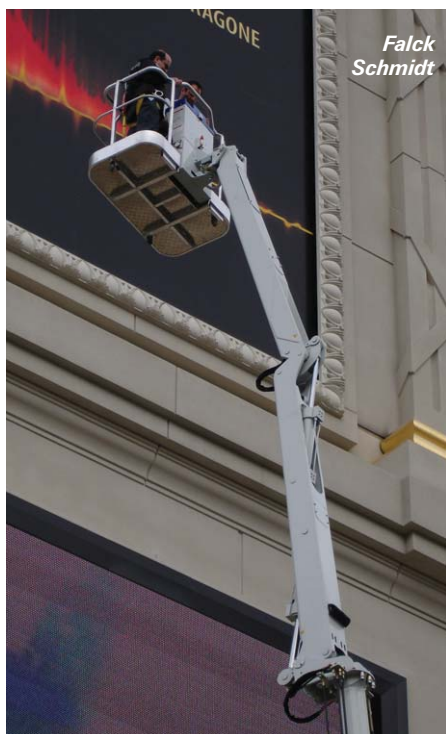

Falck Schmidt

Las plataformas de brazo telescópicas autopropulsadas están muy bien representadas en Conexpo este año, ya que los fabricantes de este tipo de plataformas son cada vez más después de un periodo en que parecía que las opciones se habían limitado. Se presentarán nuevos modelos en la feria, esto es lo que encontrará.

Le sugerimos que comience por Skyjack en medio del area azul (Blue), cuando yah an pasado dos años desde que la empresa anunció su re entrada en lasplataformas telescópicas. Skyjack realiza un buen comienzo con su gama. Las estrellas del stand serán las nuevas telescópicas de 61 y 66 pies, la de 66 pies con jib, construidas con los principios básicos de su familia de 40/45 pies. Eche un vistazo al sistema de ejes 4x4, giro de 45° y sus características centradas en el servicio.

Cruzando un pasillo se encuentra Reachmaster, que cuenta con sus plataformas telescópicas tipo araña, incluyendo: Hinowa, Denka y Falck Schmidt - la araña original. La empresa, una division de Worldlift industries, se ha convertido en un experto en acceso a grandes atrios, sus productos pasan facilmente a través de puertas convencionales e incluso suben escaleras, antes de telescopar a 50 m.

Cruzando el otro pasillo encontrará el ultimo protagonista del Mercado de las telescópicas - MEC, sí, MEC, fabricante de Tijeras, lo es a partir de esta semana de plataformas telescópicas. La empresa lanzará sus nuevas M40T y M46T, una familia de telescópicas diseñadas por ingenieros que trabajaron en Genie y UpRight. Échele un vistazo, eje oscilante, radio de giro y lo que se refiere a su customización California.

Si va por el pasillo Central encontrará al fabricante italiano de arenas Italmec, que probará el Mercado norteamericano. Si sigue por el area South Hall encontrará Bil-Jax y su nueva serie X de plataformas autopropulsadas ligeras. La nueva 45XA hará su debut, ofreciendo una altura de plataforma de 45 pies, con un peso de sólo 4.500 lbs/2,000 kgs. Se añade al modelo 36XT, lanzado el año pasado y comparte una superación de pendiente de 45%, con un despliegue de estabilizadores de solo 30 segundos.

Si sigue recto se encontrará el stand de Vertikal Press - diganos hola - y el el area Gold la primera parada sera a Snorkel/Upright, las dos marcas ahora fusionadas, ondeando la bandera de Snorkel, ya que estamos en EE.UU. Esta sera la primera oportunidad para muchos de conocer a los nuevos directivos - Tanfield, y conocer más de la estrategia de expansion del grupo.



Al otro lado del pasillo encontrará el gran stand de terex y Genie, la empresa tendrá una Buena selección de telescópicas y ¿quizás nos sorprenda con algo nuevo? Si todavía no le ha echado un vistazo a su revolucionaria articulada de 40 pies Z40/23N con sistema directo de conducción AC. Lanzada hace un año, ya está totalmente en producción.

Enfrente del otro pasillo encontrará el stand de Haulotte, donde parar es un deber. Con una tercera posición a nivel mundial, lanzarán en la feria un modelo totalmente Nuevo, la HB86TJ+ (HA28TJ+) de 86 pies, algo diferente de las telescópicas tradicionales, con un voladizo ajustado, un jib telescópico de 16.5ft/5m y una gran capacidad de carga. La empresa expondrá una completa selección de plataformas telescópicas y articuladas. No se pierda su elevador sobre mástil de 26 pies Star 26J (Star 10).

Ahora dirijase hacia la parte de atrás de la feria, donde encontrará JLG, ahora propiedad de Oshkosh, que dispone de uno de los stands más impresionantes de la feria. Mientras que no realizará ningún lanzamiento radical, ha puesto gran esfuerzo en refinar y mejorar su amplia gama de productos. También encontrará un ambiente amistoso y Buena atmósfera.

Finalmente muy cerca de ahí, Manitou, aunque no expondrá sus brazos en Conexpo, contará con un gran stand y sus directivos estarán felices de hablar sobre sus plataformas.

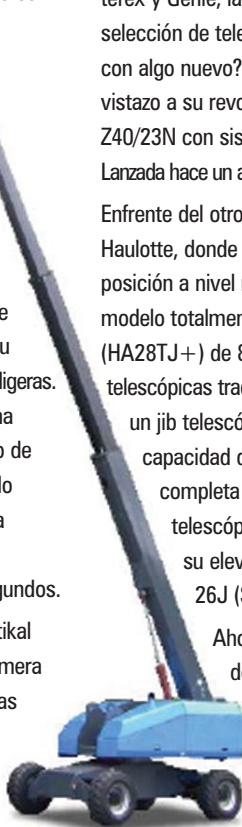

Aichi 46ft boom

POWER & PERFORMANCE



THINK RED. THINK MEC.

MEC Aerial Work Platforms delivers machines with power and performance for maximum productivity. Products include electric and rough terrain scissor lifts, telehandlers, and now self-propelled boom lifts. MEC is proud to introduce its newest family member – the industry-leading **M40T Self-Propelled Boom...**

BEST IN CLASS :

- ▶ Farthest horizontal reach
- ▶ Shortest tailswing in the industry
- ▶ Fastest boom function & drive speeds
- ▶ Highest 2wd & 4wd gradeability ratings
- ▶ Most graphically intuitive control system
- ▶ Largest range of motion oscillating axle
- ▶ Tightest inside & outside turning radius
- ▶ Greatest multi-function capability

MEC Aerial Work Platforms

1775 Park Street, #77 | Selma, CA 93662 | USA
Toll free: 1.877.MEC LIFT | 1.877.632.5438
Tel: 559.891.2488 | Fax: 559.891.2448
Email: info@mecAWP.com | www.mecAWP.com

Visit us at
ConExpo (blue lot)
Booth B-959



Manufacturer • Fabricante	Stand
Aichi	S-8907
Bil Jax	S-8417
Bravi Platforms	B-960
Custom Equipment	B-955
Genie/Terex	G-200
Haulotte	G-236
JLG	G-170
Manitou	G-195
MEC	B-959
Pop-Up	?
Skyjack	B-958
Snorkel	G-117
UpRight	G-117

Scissor lifts make up over 60% of all lifts sold, and range from big deck RT models for cladding to the smallest of push-around models for finishing work. There is plenty to see this year, although not a great deal that is really new. The most interesting development might be the arrival in North America of light weight low-level push around lifts by Bil-Jax and Pop-Up.

Begin the tour in the Gold Lot with JLG which is highlighting a range of improvements and enhancements to its popular ES electric slab models, with direct DC electric drive they lead the market in terms of battery life. On now towards the main

buildings and Haulotte's stand which is dedicated to booms and telehandlers, it has the Compact 8 (2032E) on show but that's it. Look for its video games and amazing animations.

Cross the aisle to Terex/Genie, if you have not already seen its 32ft, 32 inch wide GS3232 then this is your chance. A new Runabout might also be on display? Jump the aisle to Snorkel/UpRight to see the merged product line on display. Look for the company's compact RT scissor lifts, originally made in New Zealand and now built in both the UK and Kansas. The famous Speed Level is also on display with a number of design improvements.

Now head towards the Blue Lot but don't use the bridge! Cross over to the South Hall, pass the Vertikal booth and head for the Toyota stand where you will find the new Aichi global scissor lifts, the first small electrics with direct AC motor drive. Close by you will find Bil-Jax with its new 10ft PT10 push-around scissor which could take the low-level access market by storm.



Close by you will find Bil-Jax with its new 10ft PT10 push-around scissor which could take the low-level access market by storm.

Bil-Jax PT10



Now to the Blue Lot and in the centre you'll find Custom Equipment, the producer of low-level, light-weight self-propelled scissor lifts that are ideal for work on upper levels. The company will have its latest CE version on display along with its 10 and 14ft ANSI models.

Cross the aisle to Skyjack, one of the biggest stands in this lot. The company has some interesting plans for new scissors later in the year, if you press them you might learn more. Continue across the aisle to MEC, which has a new compact electric 4x4 scissor lift on display offering fantastic off road ability and flotation with the benefit of clean quiet performance. Last but not least look out for Bravi, the Italian producer of electric powered mast-type self propelled lifts with fantastic gradeability.

Pop Up is planning to show its push around lifts but has not committed to a stand at time of writing.

Las plataformas de tijera representan un 60% del total de plataformas vendidas, y van desde los modelos todo terreno con gran cesta para trabajos de revestimiento al los modelos más pequeños de empuje manual para trabajos finales. Hay mucho que ver este año, aunque no hay muchas novedades. El desarrollo más importante es la llegada a norteamérica de los elevadores manuales de Bil-Jax y Pop-Up.

tour al final del área Gold con JLG, encontrará toda un agama de mejoras en su conocida gama de Tijeras eléctricas ES, con manejo eléctrico DC, con lo que lideran el Mercado

en cuanto a vida de la batería. Hacia los edificios pprincipales se encuentra Haulotte, dedicado a las plataformas de brazo y telescópicos, aunque expondrán su modelo Compact 8 (2032E) y prometen tener un stand muy entretenido con video juegos y animaciones sorprendentes.

Cruzando el pasillo está Terex/Genie, si todavía no ha visto su tijera GS3232 de 32

pies 32 inch de ancho ahora es su oportunidad. Salte el pasillo hacia Snorkel/UpRight y eche un vistazo a la fusion de productos de la marca, busque las tijeras compactas todo terreno, fabricadas al principio en Nueva Zelanda y ahora con fabricación tanto en Reino Unido como en Kansas. Su famoso modelo Speed Level se expondrá con mejoras en su diseño.

Vaya hacia el área Blue (azul) pero no vaya por el Puente, cruce por el South Hall, pase el stand de Vertikal y vaya hacia el de Toyota donde encontrará las Tijeras de Aichi, con pequeñas Tijeras eléctricas con motor AC. Cerca encontrará Bil-Jax con su Nuevo elevador de

tijera de empuje manual de 10 pies PT10.

En el área Blue vaya directamente al centro donde encontrará Custom Equipment, el fabricante de Tijeras autopropulsadas de bajo peso ideales para trabajar en niveles superiores. La empresa tendrá su última version CE en exposición junto con los modelos ANSI de 10 y 14 pies. Cruzando el pasillo llega a Skyjack, uno de los stands

más grandes en este área, las empresas tienen planes interesantes en cuanto a tijeras para finales de este año, si presiona, a lo mayor le darán más información. Continúe en la misma dirección hacia MEC, la empresa tiene una plataforma 4x4 compacta eléctrica que ofrece un esplendido rendimiento fuera de carretera. Finalmente en el pasillo central encontrará a Bravi, el fabricante italiano de elevadores autopropulsados tipo mástil con excelente superación de pendiente.

Pop Up planea mostrar sus elevadores de empuje pero no dispone de stand todavía cuando acabamos de escribir el artículo.



Rising To New Heights...

Efficient, lightweight, and easily transported.
The self-propelled **X-Booms** and **Summit Series** trailer-mounted booms from Bil-Jax make it less work, to do your work.
See them in action at www.biljax.com.



X-BOOM™

AERIAL WORK PLATFORMS

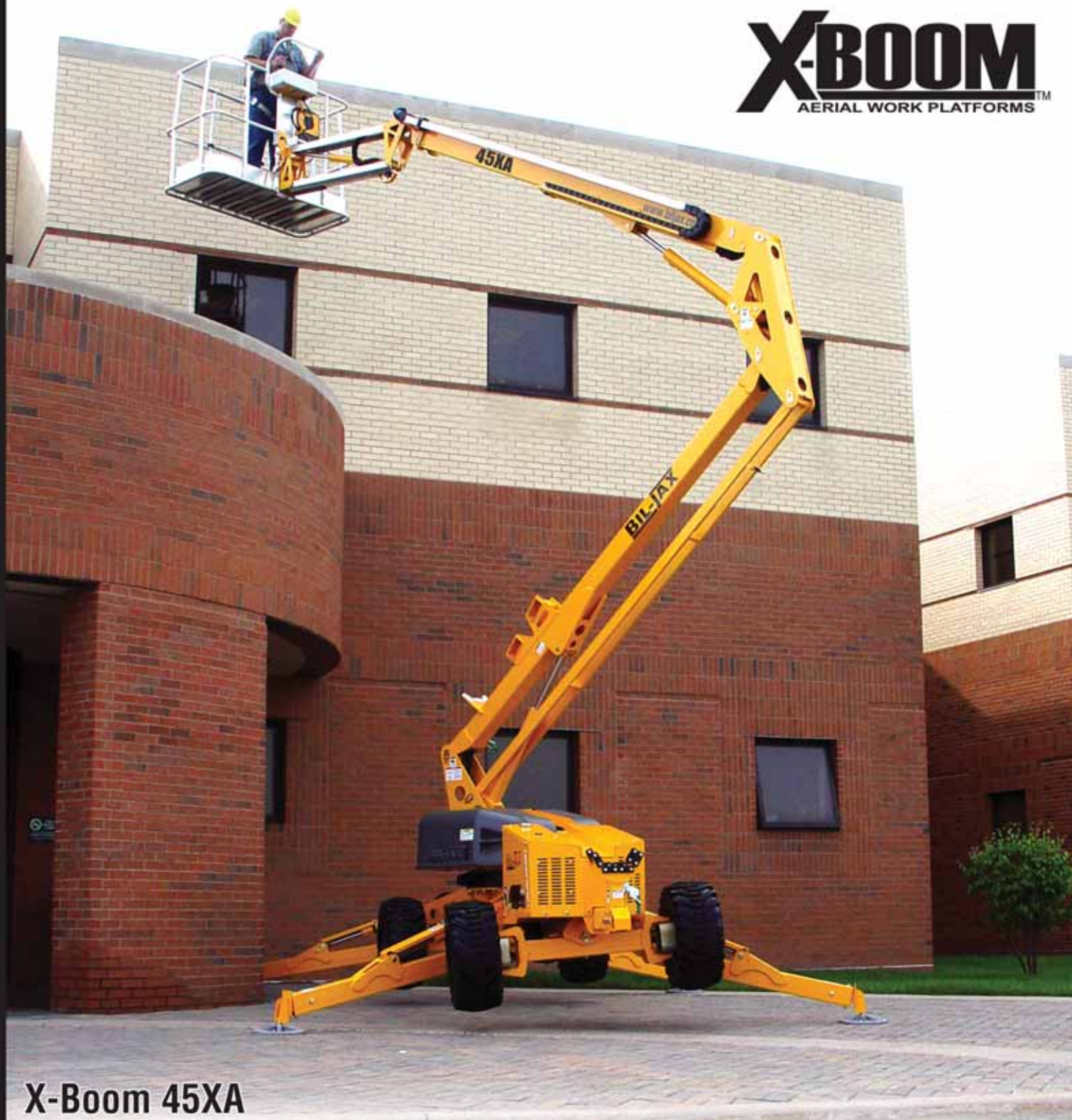

X-Boom 45XA

See Bil-Jax in action...

➤ www.biljax.com
➤ 800.537.0540

© 2008 Bil-Jax, Inc.



Booth
#8417

BIL-JAX®

Manufacturer • Fabricante	Stand
Bil-Jax	S-8417
Denka Lift	B-962
Falck Shmidt	B-962
Genie/terex	G-200
Haulotte	G-236
Instant UpRight	B-932b
Hinowa	S-16200/B-962
Italmec	C-7107
JLG	G-170
Niftylift	SZ-1000
PM/Oil & Steel	RL-43033
Snorkel	G-117
UpRight	G-117
ReachMaster	B-962
Worldlift	B-962



This is not the best of shows for trailer lifts and spiders, given their leaning towards light construction and general rental, a good number of producers are represented here.

If you head into the Central Hall at the Italian pavilion you will find Heila/Italmec which produces a range of spider lifts, but only has a small booth at this show. From here you can easily move outside to the Blue Lot where you will find ReachMaster to the rear of Skyjack. The company represents Hinowa in North America and is part of Worldlift Industries which owns both Denka and Falck Schmidt. On the stand will be at least one Hinowa spider lift, along with an FS Falcon, most likely a 28 metre model on wheels. The company has sold a good number of these to the casinos in Las Vegas, thanks to their ability to pass through a standard doorway and then reach up to over 150ft. The company is also hoping to have a 100ft unit that it has mounted on to a mid-range commercial truck.

Now make your way out towards the Silver Lot, where you will find Bil-Jax

with its range of telescopic and trailer mounted lifts. The company celebrating its 60th year in business in 2008 has no new trailer lift models for the show but will have models from its popular Summit series on display.

From here cross the street to the Gold Lot where you will find Snorkel, the company, now part of the Tanfield group, is marketing its trailer lifts under the UpRight brand, and showing the K models which have only recently been introduced to North America.

Next stop is the Terex stand where you will find Genie and its two model TZ range with 34 and 50ft platform heights. Across the aisle is Haulotte which has a small trailer lift line, but will not be highlighting them at this show. To the side of the Gold Lot is the Riviera Hall, and in the back of this building you will find the PM Group of which Oil&Steel is a member. Look for the Octopussy range of spider lifts, it should have its 12 metre model on show.

Finally go back into the Gold Lot and towards the rear is JLG which will have one of its Tow Pro models on display.



Si comienza su visita en el Hall central en el pabellón italiano se encontrará con Heila/Italmec, que fabrica elevadores de araña, pero solo contará con un pequeño stand en la feria. De aquí puede dirigirse al area Blue (azul) donde encontrará Reach Master en la parte de atrás de Skyjack.

La empresa representa a Hinowa y es parte de Worldlift Industries, dueño de Denka y Falck Schmidt. En el stand verá la última araña de Hinowa, así como una FS Falcon, lo más seguro que sea una 28 m sobre ruedas. La empresa espera tener en su stand una plataforma sobre camión de 100 pies.

Ahora diríjase hacia el área South Hall, donde encontrará Bil-Jax con su gama de telescopios y plataformas remolcables. La compañía celebra su 60º aniversario en 2008 aunque no tiene remolcables nuevas para la feria pero si expondrá modelos de su popular gama Summit.

De aquí cruce la calle al area Gold donde encontrará Snorkel, ahora forma parte de el Grupo Tanfield, y están promocionando sus plataformas remolcables bajo marca UpppRight, y los modelos K de Snorkel que acaban de lanzarse al Mercado norteamericano.

La siguiente parada es el stand de Terex, donde Genie expondrá dos modelos de su gama TZ con alturas de plataforma de 34 y 50 pies. Cruzando el pasillo se encuentra Haulotte que cuenta con una plataforma remolcable pequeña, pero que no

mostrarán en esta feria. Hacia el lado del área Gold es el Hall Riviera, y detrás de este edificio encontrará el grupo PM, donde Oil&Steel dentro del grupo fabrica plataformas de araña de su gama Octopussy y deberían exponer su plataforma de 12 m.

Finalmente vuelva hacia el área Gold y hacia el final se encuentra con JLG que contará con uno de sus modelos Tow Pro.





INSTANT

QUALITY & STRENGTH YOU CAN TRUST

there's
only one
true original

For sixty years, Instant UpRight has provided innovative access tower solutions to the world's rental market. Our tower products are highly developed, with each and every component designed for a long and productive life.

So what is it that defines quality... and how long does it take to build trust?

Visit us at Conexpo,
stand B932b



T: +353 (0)1 6209300
www.instantupright.com

**INSTANT
UPRIGHT**

GLOBAL PROVIDER OF ACCESS TOWER SYSTEMS

DEALERS WANTED IN SOUTH AMERICA

PLATAFORMAS SOBRE CAMIÓN ■ TRUCK MOUNTED LIFTS

Manufacturer • Fabricante	Stand
Altec Industries	G-270
Böcker	S-614-4
Elliot Equipment	G-248
Hydra	G-324
Palfinger	S-610
PM/Oil & Steel	RL-43033
ReachMaster	B-962
Terex Utilities	G-200
Time Condor Versalift	B-957
Versalift	B-957



Conexpo is not exactly a truck mount show although many of the companies in the market offer both truck mounted lifts and boom trucks. This year seven companies producing truck mounted lifts are exhibiting.

We begin the tour in the Gold Lot, starting with **Altec**, the largest producer of vehicle mounted lifts in North America. The company specialises in producing aerial lift devices for the lighting, signs, telecommunications, tree care and electric utility trucks with work heights of up to 130ft (39m).

From here head past towards Link Belt and Haulotte where you will find **Elliot**, which has a similar although less extensive range to Altec. It will be showing its new



70ft (24m) Skywalk 70 which is targeted at sign installation and maintenance with its 16ft long extended platform, sufficient for three people.

Continue on towards the Tadano stand and find **Hydra Platforms** which produces truck and trailer mounted under-bridge units which feature a patented scissor type separator to reach over parapets. The truck mounted units are also self propelled thanks to a tracked type outrigger system. Platforms of up to 66ft (20m) are available. If you want to call in on **Oil & Steel** the

producer of European truck mounted platforms head into the Riviera Hall where you will find its stand at the rear.

Cut across now to the Terex stand to ask about **Terex Utilities** specialist truck mounted units before heading to the Silver Lot across the road. Loader crane producer **Palfinger** has a stand, but the company has no plans at present to launch its Bison range of truck mounts in North America.

Next stop is the Blue Lot where you will find **Reachmaster**. The company, not known for its truck mounts in this part of the world, is showing a 100ft (30m) spider lift superstructure mounted onto a mid sized truck by a specialist dealer. It is looking for feedback on the installation. Our final stop is **Time Manufacturing** which owns **Condor** and **Versalift** brands. Expect to see Versalift's new VST and TEL aerials aimed at electric utility, sign and light, traffic maintenance, launched late last year at the ICUEE Show they offer working heights up to 60ft (18m).

Conexpo no es exactamente par alas plataformas sobre camión aunque muchas de las empresas ofrezcan al mercado este tipo de maquinaria. Este año siete empresas fabricantes de plataformas sobre camión expondrán en Conexpo.

Comenzamos el tour en el área Gold, comenzando con **Altec**, el mayor fabricante de plataformas

sobre camión en norteamérica, está especializado en fabricar dispositivos de elevación para alumbrado y señalización, telecomunicaciones, poda, etc., con Alturas hasta los 130ft (39m).

De aquí vaya hacia Link Belt y Haulotte, donde encontrará **Elliot**, que tiene una gama similar aunque menos extensa que Altec, mostrará su nueva Skywalk 70 de 70ft (24m)

Skywalk 70 que está diseñada para colocación de señales y mantenimiento con una plataforma extendida de 16ft de longitud, suficiente para tres personas. Continue hacia el stand de Tadano y encontrará Hydra Platforms que produce plataformas sobre camión y remolcables bajo puentes que incorporan un separador tipo tijera para lacanzar los parapetos. Las sobre camión son autopropulsadas también gracias a su sistema de estabilizadores de orugas. Las plataformas hasta 66 ft (20m) están ya disponibles. Si quiere conocer más sobre **Oil & Steel**, el fabricante italiano de plataformas sobre camión vaya hacia el Hall Riviera donde encontrará su stand al final.

Cruce ahora hacia el stand de Terex y pregunte por las unidades sobre camión especiales **Terex Utilities** antes de ir al área Silver par aver Palfinger, pero la empresa no tiene planes de momento de lanzar su gama de plataformas sobre camión Bison en norteamérica.

La próxima parada es en el área azul donde encontrará **Reachmaster**. La empresa, que no es conocida por

sus plataformas sobre camión en esta parte del mundo, expondrá su superestructura de araña de 100ft (30m) montado sobre camión de tamaño mediano. Busca feedback en las instalaciones. Nuestra parada final es **Time Manufacturing** que es dueña de **Condor** y **Versalift**. Podrá ver las nuevas plataformas VST y TEL destinadas a utilidades eléctricas, señalización e iluminación, mantenimiento de tráfico, lanzado el año pasado en la feria ICUEE, ofrecen alturas de trabajo hasta to 60ft (18m).



"Evolution is survival of the fittest." (Charles Darwin)

PARMA 16 D



www.matilsa.es

MATILSA

matilsa@matilsa.es



Booth B-955
March 11-15



Do you know...

Contractors are shortening the building construction time by using the Hy-Brid lift?

The reason behind this is the machines weight!

Contractors have even finished three months early!

We would appreciate the opportunity of explaining more benefits to you at the ConExpo in Las Vegas, NV, March 11-15.

Please call to find out more about our products and services.

866-334-0756

Hy-Brid Lifts

www.hybridlifts.com

Manufacturer • Fabricante	Stand
Alimak Hek	G-336
Avro Hoist	B-905A
Baoda /SBU Hoist	B-920
Böcker	S-614-4
Camac	G-192
Hek	G-336
Fraco	SZ-1000
Hydro Mobile	B-989
Scanclimber/Scaninter	B-977
Tractel	GP-50844
Wuxi Shenxi	C-7269C

The steady increase in the use of mast climbers in North America is reflected in their growing presence at Conexpo. At the 2005 event only two manufacturers chose to exhibit, this year there are more than triple that number.

We start the tour on the AWPT/IPAF stand in the Green Safety Zone SZ-1000 and the small booth for Canadian producer Fraco and one of its mast climbers. Fraco prides itself on producing a range of machines from light-weight trailers to heavy duty models that can be easily adapted to special applications.

Step into the Green Pavilion where you will find Tractel, which produces a range of products from Suspended platforms to permanent window cleaning units. As you pass through the Central Hall on route to the Blue Lot you might stop at Wuxi Shenxi a Chinese producer of hoists and suspended platforms. In the Blue Lot you will find



Atlantic. Ask them to show you their mast design. Avro Hoist, a Canadian dealer for new and used hoists also offers a range of hoists for rent. Baoda hoists are made in Malaysia and sold in North America by SBU hoists.

Finally at the rear of the Blue Lot is Hydro-Mobile the other big Canadian mast climber producer. The company specialises in heavy duty IC driven mast climbers and has an unusual split platform on its F series which allows one half of the platform to return to the ground or to work at another level. All from a single mast, well worth a look.

Now its off to the Silver Lot to see Böcker which produces two ranges of light duty material and passenger hoists as well as ladder type material lifts. Then on to the Gold Lot for Alimak-Hek the leading producer of mast climbers and hoists. The star of its stand will be its new modular range, which allows it to offer light, medium and heavy duty mastclimbers from a small number of components that work together and that also interchange with many of its hoist products. The company will also be showing off its remote diagnostics and recording system.

Finally in the Gold Lot is Camac, the Spanish mast climber and hoist company, exhibiting at the show for the first time. The company prices models from an extra narrow lift shaft hoist up to full size mast climber.



Scanclimber, the Finish company that produces heavy duty mast climbers that sell well on both sides of the



El incremento en el uso de plataformas sobre mástil en norteamérica se refleja en la creciente presencia en Conexpo. En la feria del 2005 sólo dos fabricantes fueron expositores, este año hay más del triple.

Comenzamos el tour en el stand de AWPT/IPAF en la zona de seguridad verde SZ1000 donde encontramos un pequeño stand del fabricante canadiense Fraco, y uno de sus elevadores de mástil. Fraco se enorgullece de fabricar máquinas desde modelos remolcables ligeros a modelos de gran capacidad que pueden adaptarse fácilmente a aplicaciones especiales.

Vaya al Pabellón Green donde encontrará Tractel, que fabrica un agama de productos desde plataformas suspendidas a unidades permanentes de limpieza de cristales. Según pase el hall central de camino al área Blue puede parar en Wuxi Shenxi, fabricante chino de elevadores y plataformas suspendidas. En el área Blue encontrará a Scanclimber, la compañía finlandesa que produce elevadores de mástil que se venden bien a ambos lados del Atlántico. Pidales que les enseñen su diseño de mástil. Avro Hoist, un líder canadiense para elevadores nuevos y usados ofrece una gama de elevadores para alquilar. Los elevadores de Baoda están hechos en Malasia y vendidos en norteamérica por SBU hoists.

Al final de el área Blue se encuentra Hydro-Mobile, el otro gran fabricante canadiense. La empresa está especializada en elevadores sobre mástil con motor IC y dispone de una plataforma inusual en su serie F que permite que la mitad del elevador trabaje a otro nivel o regrese al suelo. Todo desde un mástil único. Merece la pena un vistazo.

Ahora en el área Silver podrá ver a Böcker que fabrica dos gamas de elevadores ligeros de material y personas, así como elevadores de material tipo escalera. Si va al área Gold encontrará a Alimak-Hek, líder en plataformas sobre mástil. La estrella de su stand sera su gama modular, que ofrece plataformas ligeras, medias y pesadas desde un pequeño número de components que trabajan juntos y que se pueden intercambiar con muchos de los productos de elevadores. La empresa también mostrará su sistema de diagnóstico y grabación remoto.

Finalmente, en el área Gold encontrará a Camac, fabricante español de plataformas sobre mástil y elevadores, que exponen en la feria por primera vez. La empresa ofrece modelos extra estrechos hasta plataformas sobre mástil completos.



TO STAND THE TEST OF TIME



MANITOU building range : to stand the test of time.

Manitou – the world leader in rough-terrain fork-lifts – offers you more than 50 models of excellence.

Our spirit of innovation and our demand for quality, acknowledged since 1957, are your guarantee of ultra-reliable machines.

All our services on www.manitou.com

 **MANITOU**

Manufacturer • Fabricante	Stand
Bobcat	G-100
Carelift	G-300
Case	N-1609
Caterpillar	G-140
Faresin	RP-34005
Gehl	N-2601
Genie/Terex	G-200
Gradall Industries	G-137
Harlo Products	B-922
Haulotte	G-236
Hinowa	S-16200
Hunan	N-1041
JCB	G-160
JLG	G-170
Komatsu	N-1009
Liebherr	G-374
Lull	G-170
Manitou	G-195
MEC	B-959
Mustang	N-2741
New Holland	G-120
Pettibone	G-259
Sellick Equipment	B-924
Skyjack	B-958
Skytrak	G-170
Taylor	C-6513
Terex	G-200
Xtreme	G-147
Zoom Boom - Carelift	G-300



global producers are building the same products on both sides of the Atlantic. When it comes to larger models however the simple rugged high boom design is still preferred in this market over the low boom European models with their super deluxe cabs. The producers are different too. JLG with its SkyTrack, Lull, JLG and Gradall brands clearly leads the market, while products unheard of in Europe such as Pettibone, Gehl, Sellick, Mustang and Carelift each also have a decent share of the market. Worldwide market leaders Manitou

and JCB struggle here to win and hold market share well below what they normally expect.

So with that introduction let's begin our tour in the Gold Lot where most of the major brands are located and Manitou which has the world's largest telehandler on show. The company has a wide range of products on display including its massive MHT10160 with 36,000lbs (16 tonnes) lift capacity and most likely its larger brother the MHT10210

which can handle 46,000lbs (21 tonnes). Both models feature a maximum lift height of just under 32ft (10 metres) and an outreach of 18ft (5.5 metres). While here do take a look at the new, larger version of the three wheeled Twisco.

Now cross the aisle to North American market leader JLG with its brands Gradall, Lull and

Skytrak. Its latest model, its first truly global product, is the JLG super compact G5-18A (2505 in Europe) with a 5,500 lbs (2,500kg) lift capacity of 1,850lbs (840kg) at its fully extended reach of 11ft (3.3m). Its key features are its compact dimensions, including an overall height of just 76 inches (1.9m).

Next stand over is JCB, still claiming to be the global market leader but in reality neck and neck with Manitou. JCB is showing off the US-built versions of its new Hi-Viz range with improved all round visibility. Two aisles over is the Caterpillar stand with its new Cat-Alliance models built by JLG, including its version of the G5 super compact telehandler.

Now turn left onto the most unusual stand at the show, that of local producer Xtreme. Owned by rental veteran Don Ahern, the Xtreme range is designed from scratch for the rental market. You will also notice that its compact models are made by Dieci in Italy and rebranded Xtreme for the US market. An unusual exhibit on the stand is a portable wash-down facility with built in filtration system. It is well worth a look no matter what equipment you are interested in.

Continue on to the Pettibone stand, where the company is showing its new Traverse series T1157 with 57ft (17.3m) lift height, 11,000lbs (5,000kg) lift capacity and amazing

70 inches (1.75m) of horizontal boom travel. The new model will be ready to ship later in the year. Cut across diagonally to Liebherr, it has said that it will have one of its new telehandlers on display, hardly a North American product, but worth a look.

Back-track now to Haulotte in order to see its recently launched Top-Lift HTL telehandler, the 55ft-9,000lbs /17metre-4,000kg European style low-boom model most likely in all black livery. Haulotte promotes this range as being rental proof, designed for individuals with less than perfect training - idiot proof?.

Cross over to Terex now where you will find the updated 5,500lbs-19ft (2,500kg-5.8m) Genie GTH5519 compact telehandler with its improved performance, easier service access and new cab. At the far end of the Gold Lot is Carelift, now part of Skyjack, the company is launching the new 12,000lbs-32ft (5,400kg-10m) ZB12032. The unit will be displayed with a 10,000lb pipe grab as this is one of its key applications. This would be the time to head into the Riviera hall to see Faresin of Italy.

Now head for the bridge and en-route you will pass Bobcat which is showing its new V417, 4,800-17ft (2,200kg/5.2m) VersaHandler TTC, the fourth model in its VersaHandler telehandler line and the first to offer the 'Bob-Tach' attachment mounting system which will take certain attachments from skid-steer and other loaders.

Now it is over to the North Hall where you will find Case, Gehl, Komatsu and Mustang. Case-New Holland has three new European built TX telehandlers while Gehl will show its DL and RS series along with the CT model that it badges from Manitou. Finally Sellick is located in the Blue Hall.





MAASTRICHT
SEPTEMBER
17 - 18 - 19



The meeting place for the worldwide access industry

Visitors to **APEX 2008** will see the most concentrated display of access equipment in the world.

Because **APEX** is dedicated solely to the access industry, it is recognised as the industry's main exhibition.

But **APEX** is not just an exhibition, it is an industry event. Alongside the exhibition there are product demonstrations and the free **APEX** conference. *The world's access industry will be at APEX 2008. Be part of it.*

The APEX website also has information on exhibitors, the conference, hotel booking, free shuttle bus and much more.

Register online NOW for a FREE entry:

www.apexshow.com

In co-operation with:



Sponsored by:



MAASTRICHT EXHIBITION AND CONGRESS CENTRE



THE NETHERLANDS



Opening times:

17 Sept. 10.00 - 18.00 h.
 18 Sept. 09.30 - 18.00 h.
 19 Sept. 09.30 - 17.00 h.

Contact Ms. Joyce Eeftink (Project manager). Tel: +31 (0)547 27 15 66. E-mail: joyce@ipi-bv.nl www.apexshow.com

Manufacturer • Fabricante	Stand
Bobcat	G-100
Carelift	G-300
Case	N-1609
Caterpillar	G-140
Faresin	RP-34005
Gehl	N-2601
Genie/Terex	G-200
Gradall Industries	G-137
Harlo Products	B-922
Haulotte	G-236
Hinowa	S-16200
Hunan	N-1041
JCB	G-160
JLG	G-170
Komatsu	N-1009
Liebherr	G-374
Lull	G-170
Manitou	G-195
MEC	B-959
Mustang	N-2741
New Holland	G-120
Pettibone	G-259
Sellick Equipment	B-924
Skyjack	B-958
Skytrak	G-170
Taylor	C-6513
Terex	G-200
Xtreme	G-147
Zoom Boom - Carelift	G-300



muchos fabricantes ya construyen a los dos lados del Atlántico. Cuando se trata de grandes modelos se prefiere el diseño simple que los modelos europeos con cabina de lujo. Los fabricantes son diferentes también según las zonas, con JLG con sus marcas SkyTrack, Lull, JLG y Gradall que lideran el mercado, mientras que productos que casi no han sonado en Europa como Pettibone, Gehl, Sellick, Mustang y Carelift tienen una importante cuota de mercado. Los líderes a nivel mundial Manitou y JCB estarán en Conexpo para ganar cuota y mantenerla.

Conexpo se ha convertido en una feria de manipuladores telescópicos, con 25 marcas exponiendo este año. Después de tres años desde la edición anterior se ha notado una suavización del diseño entre fabricantes norteamericanos y europeos. Esto ha ocurrido sobre todo en el Mercado de las telescópicas compactas, ya que muchos productos europeos se han exportado a Norteamérica y

Con esta introducción comenzamos el tour en el área Gold, donde se encuentran las marcas más importantes y que mayor comienzo que Manitou, que expondrá el manipulador telescópico más alto del mundo. La empresa cuenta con una extensa gama incluyendo el modelo MHT10160 con 36,000lbs (16 toneladas) de capacidad de elevación y su hermano mayor, el MHT10210, que puede elevar hasta 46,000lbs (21 toneladas). Ambos

modelos ofrecen una altura de elevación por debajo de 32ft (10 m) y un alcance de 18ft (5.5 m). Mientras está ahí, échele un vistazo a la versión superior de su manipulador de tres ruedas Twisco.

Ahora cruce el pasillo hacia el líder en Norteamérica JLG. Su último modelo, su primer producto realmente global, es el manipulador super compacto

G5-18A (2505 en Europa) con 5,500 lbs (2,500kgs) de capacidad de elevación o 1,850lbs (840kgs) a su alcance máximo de 11ft (3.3m).

Su principal característica son sus dimensiones compactas, incluyendo una altura total de 76 inches (1.9m).

El siguiente stand es JCB, todavía proclamando ser el número uno, pero muy disputado con Manitou.

JCB expone la versión norteamericana de su nueva gama Hi-Viz con visibilidad mejorada. Dos pasillos más allá se encuentra el stand de Caterpillar con sus nuevos modelos Cat-Alliance construidos por JLG, incluyendo su versión del super compacto G5. Ahora tuerza a la izquierda hacia el stand más raro de la feria, el fabricante local Xtreme.

Perteneciente al veterano del alquiler Don Ahern, la gama Xtreme está diseñada para arañar al mercado del alquiler. Se dará cuenta de que sus modelos compactos están hechos por Dieci en Italia y renombrados Xtreme para el mercado norteamericano.

Otro producto inusual en el stand será una fábrica portátil de lavado con sistema de filtración incorporado. Merece la pena verlo.

Continúe hacia el stand de Pettibone, donde la empresa muestra su nueva Serie Traverse T1157 con 57ft (17.3m) de altura de elevación, 11,000lbs (5,000kgs) de capacidad de elevación y (1.75m) de traslación horizontal del brazo.

El nuevo modelo estará

listo para finales de este año.

Si se va en diagonal hacia Liebherr, se dice que podrá ver uno de sus nuevos manipuladores, no es un producto norteamericano, pero merece la pena verlo.

Vuelva hacia Haulotte para ver su recientemente lanzado manipulador Top-Lift HTL, el modelo de 55ft -9,000lbs /17m-4,000kgs de estilo europeo, en color negro seguramente. Haulotte promociona el producto como ideal para empresas de alquiler, diseñadas para individuos con menos que una formación perfecta - a prueba de idiotas?. Cruce a

Terex donde encontrará el renovado manipulador compacto de 5,500lbs-19ft (2,500kg-5.8m) Genie GTH5519 con su rendimiento mejorado, fácil servicio y una nueva cabina. Al final del

área Gold encontrará Carelift, ahora parte de Skyjack, la empresa estará lanzando el nuevo ZB12032 de 12,000lbs-32ft (5,400kgs-10m). La unidad estará expuesta con un agarrador de tubos de 10,000 lb como una de sus aplicaciones. Ahora será hora de ir hacia el Hall Riviera para ver a Faresin, de Italia.

Ahora diríjase al Puesto y pasará Bobcat, que tendrá expuesto su nuevo modelo V417 -de 4,800-17ft (2,200kg/5.2m)- VersaHandler TTC, el cuarto modelo de su línea VersaHandler y el primero en ofrecer el implemento de sistema de montaje 'Bob-Tach' que puede incorporar ciertos implementos.

Ahora diríjase al pabellón norte donde encontrará Case, Gehl, Komatsu y Mustang. Case-New Holland tiene tres telescópicos europeos TX mientras

Gehl mostrará sus series DL y RS junto con su modelo CT con su insignia de Manitou. Finalmente Sellick se sitúa en el hall Blue.



Manitex

The Leader In Boom Truck Innovation

More Models...

More Markets...



More Crane

Meet the new 5096S



Manitex continues its...

commitment to new **product development**, driven by **customer input**.

More than 20 new models since 2003.

What's Your Market?

Need a Taxi? Our latest offering is the most versatile Manitex yet. The new **5096S Truck Mounted Crane** with 152' tip height, offset jib and a strong load chart is an unbeatable value that replaces traditional, more expensive, solutions.

If it's **Power Distribution**, the **124SX**, **35124C** and **40124S** provide the widest selection of options. All three platforms have man basket heights to 166'.

Heavy Lifts pay the bills? The **40124SHL** provides more capacity at radius than any boom truck in the market.

If **Duty Cycle** is the key, all **Manitex S** and **SX** series boom trucks are configured with feather soft controls for multifunction operation, continuous rotation, retracted outrigger charts and oil coolers as standard. The **30112S**, our latest addition to the S series line, reaches new heights with a maximum tip height of 168'.

Payload necessary? The **26101C** weighs up to 5,000# less than competitive models and the **30102C** provides up to 10,000# payload on a 54,000 GVWR chassis.

Wireline Work? The **102WL** provides 30 ton crane capacity and the **124WL** offers 134' tip height without a jib.

Truss work is made efficient with the **2281T**, the highest capacity tractor mount on three axles.

Five new **SC** series models support **Sign Erection and Service** with working heights from 62' to 97'. Our newest, the **SC-85** provides 85' working height and 12 ton crane capacity.

New Market Solutions?.....Ask ManiteX!

All Manitex Products
Backed by

UPTIME

Comprehensive
Product Support

Manitex
MOVING FORWARD FASTER

3000 South Austin Avenue
Georgetown, TX, USA 78627-1609
Tel: 512-942-3000 • Fax: 512-863-3776
www.manitex.com

GRÚAS HIDRÁULICAS SOBRE CAMIÓN ■ TRUCK LOADER CRANES

Manufacturer • Fabricante	Stand
Atlas -Terex	G-200
Altec Industries	G-270
Auto Crane	C-4233
Elliot Equipment	G-248
Furukawa - Unic	RL-44013
Heila Truck Loaders	C-7107
Hiab	RL-45013
Iowa Mold Tooling	N-2141/S813
Manitex	G-330
Palfinger	S-610
PM	RL-43033
Stellar Industries	G-230
Summit	N-2859
Tadano	G-328
Terex	G-200



its outrigger design. Another new crane, seen at last year's ICUEE is the 301125 with its 'ride around' operators control station.

Right behind you is the **Tadano** stand with two regular boom trucks and a new 35 ton crane, the TM35100 with a fully enclosed cab that owes more to a regular truck mount. The 10 ton TM1052 and 20 ton TM20110 will also be on display.

The Riviera Hall is behind the Gold Lot, if you head inside you will find **PM, Hiab, Furukawa-Unic** and **Heila**. On the PM stand you can see the PM85SP, the largest model in the company's line-up, making its North American debut. The 85027SP+J1204.20 version will be on display with a maximum hook height of 108 feet (33 m) at which it can lift 2,010 lbs (910 kg).

Esta es una categoría mezclada, desde las grúas telescópicas más pequeñas, las grúas europeas tipo articulado hasta los camiones grúa de 50 ton que tienen más en común con una grúa sobre camión que una grúa autocargante.

Los stands están repartidos por toda la feria, por lo que comenzaremos en el área Gold con los fabricantes sobre camión. Empezamos con **Altec**, el fabricante de grúas y plataformas. Altec tiene grúas desde 18 a 38 tons de capacidad de elevación.

Ahora diríjase a **Manitowoc** y pasará por **Elliot Equipment** que dispone de camiones grúa utilitarios. Casi cruzando el pasillo está el impresionante stand de Manitowoc, donde encontrará el fabricante de grúas sobre camión **National crane**, con el modelo 900H en exposición.

Cruzando el pasillo está **Manitex**, que mostrará su nuevo modelo de 50 ton 50110S con su pluma de 110ft y máxima altura de trabajo de 164ft. Echele un vistazo a su diseño es estabilizadores. Otra nueva grúa, vista el año pasado en ICUEE es el modelo 301125 con estación de control.

Justo detrás de Ud. se encuentra **Tadano** con dos grúas sobre camión y una nueva de 35 ton, la TM35100 con cabina totalmente cerrada, que parece más una sobre camión que una autocargante. La TM-1052 de 10 ton y la TM20110 de 20 ton estarán expuestas.

El Hall Riviera está detrás del área Gold, si va hacia allá encontrará **PM, Hiab, Furukawa-Unic y Heila**. En el stand de PM podrá ver la PM85SP, el mayor modelo de la compañía que hace su debut norteamericano. Una versión de la 85027SP+J1204.20 estará expuesta con una altura máxima e gancho de 108 feet (33m) donde puede elevar 910 kgs.

La unidad está equipada con giro continuo, sistema de manejo Power Tronic de PM, que proporciona un continuo flujo de información a la pantalla control remoto y a la unidad central, instalada en la columna de la grúa.

De vuelta al área Gold y un paseo hacia el puente verá el stand de **Terex**, que expone tanto grúas sobre camión como las autocargantes hidráulicas de **Terex Atlas**. Su mayor exposición será el modelo BT 4792 de 21291 kg de capacidad y altura de 44 m, una plataforma para dos personas puede acoplarse de manera opcional para aumentar la versatilidad, mientras el indicador electrónico del momento de carga y los dispositivos anti bloqueo son de serie junto con la estación dual de control.

Diríjase al área Silver donde encontrará **IMT y Palfinger**. Espere a ver una gama de equipos de grúas, carretillas para acoplar en camiones, encabezado por su modelo PK150002, grúa hidráulica autocargante de 39,864 kg.

This is a very mixed category, ranging from the smallest telescopic service cranes to European type articulated cranes to 50 ton boom trucks that have more in common with a traditional truck mounted mobile crane.

Stands are dotted all over the show, so we will begin in the Gold Lot with the boom truck manufacturers. We start with **Altec** the crane and aerial lift producer which has examples of its boom truck range from 18 to 38 tons lift capacity.



Now head towards Manitowoc passing **Elliot Equipment** en-route, with its range of utility boom trucks. Almost across the aisle is the huge **Manitowoc** stand, where you will find leading boom truck manufacturer **National Crane**. The company has a model 900H on display.

Cross the aisle to **Manitex** which is showing its new 50 ton 50110S with its 110ft main boom and 164ft maximum tip height. Take a look at



The unit is equipped with continuous slewing and PM Power Tronic electronic management system, which provides a continuous flow of information to the remote control screen and central control unit.

Return to the Gold Lot and head towards the bridge to the **Terex** stand. Terex has both a boom truck line and the **Terex-Atlas** articulated loader crane range in its armory. Its main exhibit is the **Stinger**-class BT 4792 47,000lbs lifting capacity /144ft tip height. An optional two man work platform can be quickly connected to increase versatility, electronic load moment indicator and anti-two-block devices are both standard along with dual control stations.

Head over the road now to the Silver Lot where you will Find **IMT** and **Palfinger**. Expect to see a range of the company's cranes, piggy back forklifts and tail lifts, topped by the PK150002 -88,000 lb knuckle boom crane.

ANTI-COLLISION FOR CRANES

The international expertise

Shipyard - Singapore

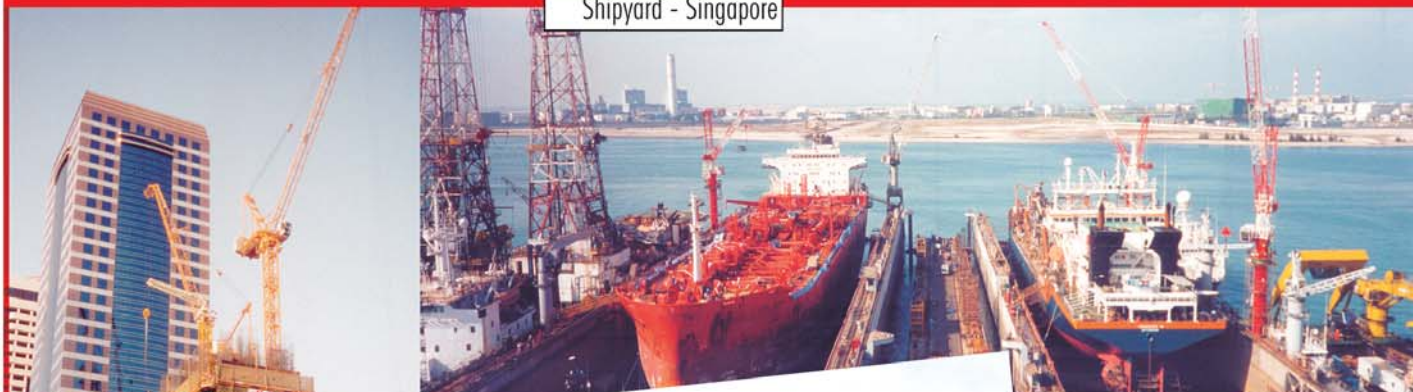

Buildings - Dubaï



Roissy Charles de Gaulle - Paris

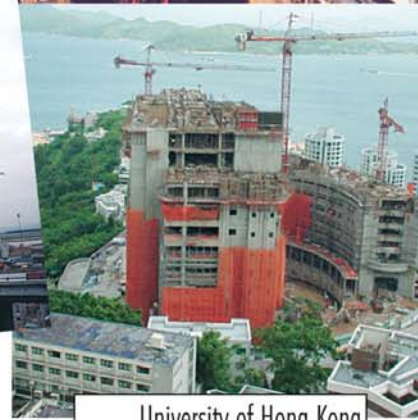

University of Hong Kong

Anti-collision and zoning systems
Site supervision - Anemometers - Airbeacons



See us at stand No.
B-901
in the blue lot



Certification ISO 9001 No. 0109-2001-FR-COFRAC-QUA

7 rue de la Chapelle - Z.I. les Richardets - 93160 Noisy-le-Grand - France
Tel. : +33 (0) 1 55 85 90 40 - Fax : +33 (0) 1 43 03 34 03



e-mail : smie@smie.com

<http://www.smie.com>

Manufacturer • Fabricante	Stand
Remote controls, LMI's and Safety systems • LMI'S, control remoto y sistemas de seguridad	
Ascorel	S-12321
Brigade Electronics	S-17801
Crane Dispatch Software	N-1300
3B6	S-18127
Cranesmart Systems	G-193
H J Hirtzer	S-847
Hirschmann	G-335
Itowa	S-18004
Kruger - Hirschmann	G-335
Laser Technology	C-6286
Load Systems International	G-196
Loadwise	C-4867
Moba	S-16530
McKee Communications	C-4029
Omnex Control Systems	C-4259
Orlaco	B-953
PAT - Hirschmann	G-335
Rayco-Wylie	B-944
SMIE	B-901
Trimble	S-17411
Remote Controls • Control Remoto	
Autec	S-10711
Cavotec	C-7590
Crane Boss	GP-51242
HBC Radiomatic	G-122
Hetricnic	G-338
Ikusi	C-4369
Omnex	C-4259
Robinson Engineering	GP-51242
Tele Radio	RP-37032

The pace of development of electronics over the last few years has been staggering and is one of the fastest growing areas for cranes and lifting equipment. Remote controls are rapidly becoming a standard feature on loader cranes and growing in

other areas of the industry. Meanwhile load indicator and overload systems have both fallen in price and thanks to wireless technology have become much easier to retrofit to older cranes. Tower crane safety has also become a major issue putting devices such as the increasingly sophisticated and reliable anti-collision devices and jib/boom tip cameras. This year's Conexpo brings a good many manufacturers of this type of equipment together. Here are a few highlights.

Load Systems International is showing its wireless load indicator components including load cells, load pins, line riders, boom angle, list/trim angle, wind speed, hook radius and anti-two block switches. It also has two way radio communications to a range of 4,000ft and benefits from all sensors powering off when the display is turned off. **3B6** will have several products aimed at rated load monitoring,



the company is also a major supplier of overload devices for Aerial lifts. **Hirschmann Automation and Control**, which includes **PAT** and **Krüger** among its businesses, is launching a new scalable mobile controller system for cranes and lifts. It can be built up to monitor as many of the machine's functions as desired as well as incorporating the overload system, load moment indicators and sensors. Also ask about its Maestro LMI for retrofitting to older cranes.

Regardless of crane make or model, lattice, hydraulic, boom truck or special application, **Rayco-Wylie Systems** - pioneers of the first crane overload warning system - can probably provide a solution for the specific application from its vast array of equipment. Ask about its views and solutions on retrofitting Load indicators to older cranes.

A visit to **Orlaco** is worth a trip in the Blue Lot. The company makes boom/jib tip cameras with displays

in the operators cab, one day these devices will be standard on all cranes.

SMIE the longest established producer of tower crane anti-collision and zoning systems is launching its latest generation anti-collision system - the AC243 for up to 30 tower cranes, its SGC240 a data logging system for site supervisors and the DLZ342 advanced operator display, data logger and zoning system.



El ritmo de desarrollo de la electrónica en los últimos años ha sido increíble y es una de las áreas que más ha crecido para las grúas y plataformas. El control remoto se ha convertido en una característica de serie en las grúas hidráulicas autocargantes y están creciendo en otras áreas de la industria. Mientras, los indicadores de momento de carga y sistemas de sobrecarga han bajado sus precios gracias a la tecnología sin cables. La seguridad en grúas torre se ha convertido en una cuestión clave incluyendo dispositivos anti colisión y cámaras para las grúas.

Este año Conexpo reúne muchos fabricantes de estos equipos, aquí hay algunos destacados.

Load Systems International muestra su indicador de carga sin cables incluyendo celdas de carga, clavijas de carga, ángulo de pluma, velocímetros y dispositivos anti bloqueo. Ofrece dos comunicadores de radio de dos vías hasta 4,000ft y se beneficia de todos los sensores cuando la pantalla está apagada. **3B6** tendrá varios productos destinada a la monitorización de



carga, la empresa ofrece dispositivos de sobre carga para plataformas aéreas. **Hirschmann Automation and Control**, que incluye **PAT** y **Krüger** dentro de su negocio, lanza un nuevo sistema de control móvil escalable para grúas y plataformas, puede ser montado para monitorizar tantas funciones de la máquina como desee, así como incorporar el sistema de sobre carga, indicador del momento de carga y sensores. Pregunte por su Maestro LMI para modernizar las grúas antiguas.

Independientemente del modelo de grúa y tipo, celosía, hidráulica, autocargante o especial, **Rayco-Wylie Systems** - pioneros con el primer sistema de aviso de sobre carga - puede probablemente ofrecer una solución para aplicaciones específicas. Pregunte por sus soluciones para modernizar indicadores de carga en las viejas grúas.

Una visita a **Orlaco** merece la pena, así que diríjase al área Blue, la empresa fabrica cámaras para plumín de las grúas, seguro que un día estas cámaras serán de serie en las grúas.

SMIE, el fabricante más establecido de sistema anti colisión de grúas torre lanza la última generación de este sistema - el AC243 que sirve hasta para 30 grúas, su SGC240 un sistema de datos para supervisores y la pantalla avanzada para operador DLZ342.



THE SPECIALIST IN ASSISTANCE FOR TOWER CRANE DRIVING SECURITY TECHNOLOGIES



**FOR TOWER CRANES
AND BUILDING SITES**

■ GUARANTEEING SECURITY

■ OPTIMIZING PRODUCTIVITY

■ HOTLINE ASSISTANCE

AGS IS SPECIALIZED

**in the analysis, the advice,
the recommendation
and the implementation
of customized solutions
to overcome safety,
organizational and production
constraints on building sites.**

AC3 ANTI COLLISION SYSTEM FOR TOWER CRANES



● SUPPLY BOX

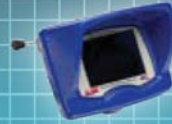

● INTUITIVE TOUCH SCREEN

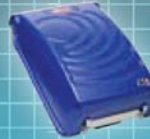

● CENTRAL PROCESSING UNIT



● RADIO



● FLASH

SF3 ELEVATED OBSTRUCTION LIGHTING SYSTEM FOR TOWER CRANES



● BOX



● BATTERY



● FX 3

AN3 ANEMOMETER FOR TOWER CRANES

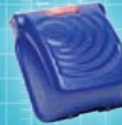

● CENTRAL PROCESSING UNIT



● SCREEN DISPLAY



● ALARM KIT



● ANEMOMETER PROBE

www.ags-btp.fr



A COMPLETE RANGE OF INNOVATIVE PRODUCTS !

AGS RHÔNE-ALPES (headquarter) - 11, rue Balzac - 69150 DÉCINES - tél. : 33(0)4 37 42 15 00 - fax : 33(0)4 37 42 15 01
AGS CENTRE - 150, route d'Orléans - 45140 INGRE - tél. : 33(0)2 38 91 48 97 - fax : 33(0)2 38 91 45 32
AGS NORD - PAS DE CALAIS - 295, rue de la Lys - 59253 LAGORGUE - tél. : 33(0)3 28 48 26 42 - fax : 33(0)3 28 48 71 96

AGS ILE-DE-FRANCE - 1, route de Longjumeau - 91380 CHILLY MAZARIN - tél. : 33(0)1 69 34 68 19 - fax : 33(0)1 64 48 81 06
AGS NORD EST - 4, rue de la madeleine - 54000 NANCY - tél. : 33(0)3 83 19 06 77 - fax : 33(0)3 83 20 19 42
AGS SUD OUEST - Lieu-dit Beylouagues - 32140 LALANNE ARQUE - tél. : 33(0)4 37 42 15 00 - fax : 33(0)4 37 42 15 01

Position ≠ Control

With a proud legacy in position sensing and control, our range is designed and built to deal with the OEM Construction Vehicle market's toughest challenges.

Reliable – Tough – Accurate – Available!

- Linear Position Sensors to 5000mm
- In-cylinder Linear Sensors
- Contactless and Sealed Rotary Position Sensors
- Valve Position Transducers
- Single and multi-axis Joystick Controllers

Penny + Giles industrial sensors and controllers are performance critical components throughout the industrialised world, where our reputation for innovative technology, creative design, manufacturing excellence and world-class customer support have delivered the right solutions time after time.

In the harshest applications that the Off-Road Construction industry can throw at us, our position sensors continue to prove their pedigree. A pedigree that also shows itself in our unique range of single and multi-axis Joystick Controllers.

Whatever kind of position sensing or control application you've got, it looks like you've just found the solution!

Phone or e-mail for a Product Range catalogue today!

➤ **Penny+Giles Controls Ltd**
15 Airfield Road, Christchurch, Dorset, BH23 3TG, UK
Tel: +44 (0) 1202 409409 E-mail: sales@pennyandgiles.com

OFF ROAD HIGH PERFORMANCE POSITION AND CONTROL

Penny+Giles

A Curtiss-Wright Company

www.pennyandgiles.com



Manufacturer • Fabricante	Stand
Components • Componentes	
American Crane & Tractor Parts	H-24017
Atlanta Trading	GP-50607
Berco	N-2902
Cavotec	C-7590
Centranz	GP-51329
Conveyor Components	C-6338
Curtis Wright	S-15226
Brevini	S-15327
Bosch Rexroth	S-13013
Dana	S-16313
Dica	S-9821
Double Coin/CMA	S-12621
EBC Industries	S-17827
Friction Marketing	C-4759
Getz Enterprises	S-12431
Gosan Crane Components	C-4743
Imo USA	C-4033-8
Lube-A-Boom	S-550
Mailhot Industries	GP-50829
North American Hydraulics	S-13819
Optima Batteries	S-17330
Opus Electronics Inc	C-4033-11
Oriental Engineering Works	S-17713
Partsmaster	C-4947
Penny & Giles	S-15226
Pirtek	S-17819
Power-Packer	S-17911
Rotzler	C-6282
Samek Corporation	GP-50245
Simplex	S-17231
Solideal	G-366
SSAB Hardox	C-4168
Tifco Industries	S-17408
Timco	B-951
Track One	S-12807
Tulsa Winch	C-6313
Wachendorff Elektronik	C-4033-11
Weldox Steel	C-1468
ZF Industries	S-16039
Lifting Equipment • Equipos de Elevación	
Actek Mfg	GP-50509
Alturamats	S-11407
ARI-HETRA	GP-50629/ RL-44030
Arrow Material Handling Products	
Auto Crane	C-4233
Böcker	S-614-4
BVA Hydraulics	S-17431
Caldwell Group	S-9145
Crosby Group	C-4455
Energpac	S-17005
Extreme Outback Products	S-12310
F & M Mafoo	S-18027
Feterl Manufacturing	G-387
Gunnebo Johnson	G-307
Hyda-Tech International	S-16253
Hydraulic Power Systems	S-884
iHC Fundex Equipment	S-19100
Independent Parts & Service	C-4345
Kinshofer Liftall	S-19101
Kundel	C-4432
Lift Equipment	GP-51011
Lift Systems	B-971
Lift-All	GP-50739
Lifting Technologies	G-325
Lug-All	S-9928
Miller Products	C-7589
Noblelift Equipment	C-7269B
Ramsey Winch	RP-36017
RGC/Reimann & Georger	S-8833
Rope Block	RL-45023
Sellstrom Manufacturing	H-23026
Sicom North America	S-8852
Signature Fencing & Flooring	GP-50809
Spanco	S-9928
Stertil-Koni	B-956
SwapLoader	G-301
Thern	S-9145
Wimag	S-614-3
Engines • Motores	
Cummins	S-16013
Deutz	S-16538
Hatz Diesel	S-16405
Kubota Engine	S-16049
Mitsubishi Engine	S-17627
MTU Detroit Diesel	S-16127
Perkins	S-15927
Southwest	S-8551
Volvo	G-134
Wire Rope • Cables	
Bethlehem - WireRope	C-4913
Bridon American	C-4027
Casar - WireCo	C-4459
Extreme Outback	S-12310
Lift-All Co	GP-50739
Twin City Wire	C-7573
WireCo	C-4459
WRCA - WireCo	C-4459
WireRope Works	C-4913

The number component companies catering for the lifting industry has blossomed at this year's Conexpo. Do take the time to visit them and find out what's new and what's on the horizon. Some suppliers will also want to pick your brains giving you a small chance to influence future developments. This is also a good opportunity to find new suppliers or pick up some new ideas.

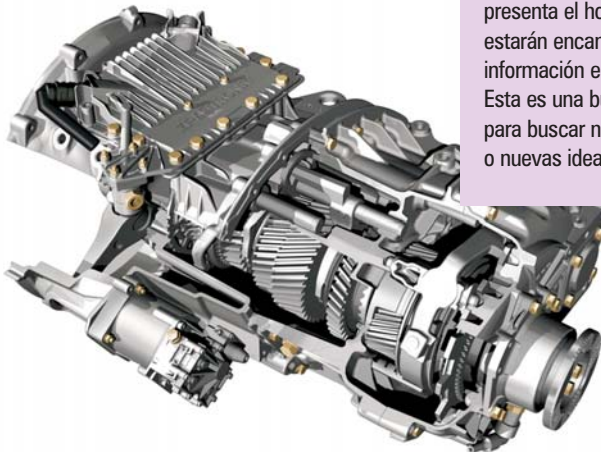

El número de empresas relacionadas con components de la industria de la elevación se ha incrementado de manera sorprendente en estos últimos años de Conexpo. Tómese su tiempo para visitar lo que es nuevo y lo que presenta el horizonte. Algunos distribuidores estarán encantados de ofrecerle completa información en futuros desarrollos. Esta es una buena oportunidad para buscar nuevas empresas o nuevas ideas.



JASO, Equipos de Obras y Construcciones, S.L.

Ctra. Madrid-Irún, Km. 415 - 20213 IDIAZABAL (Guipúzcoa) Spain

Tel.: +34 943 18 70 00

E-mail: jaso@jaso.com

Fax: +34 943 18 70 20

www.jaso.com



TOWER CRANES



Visit us on the
Silver Lot
S 553

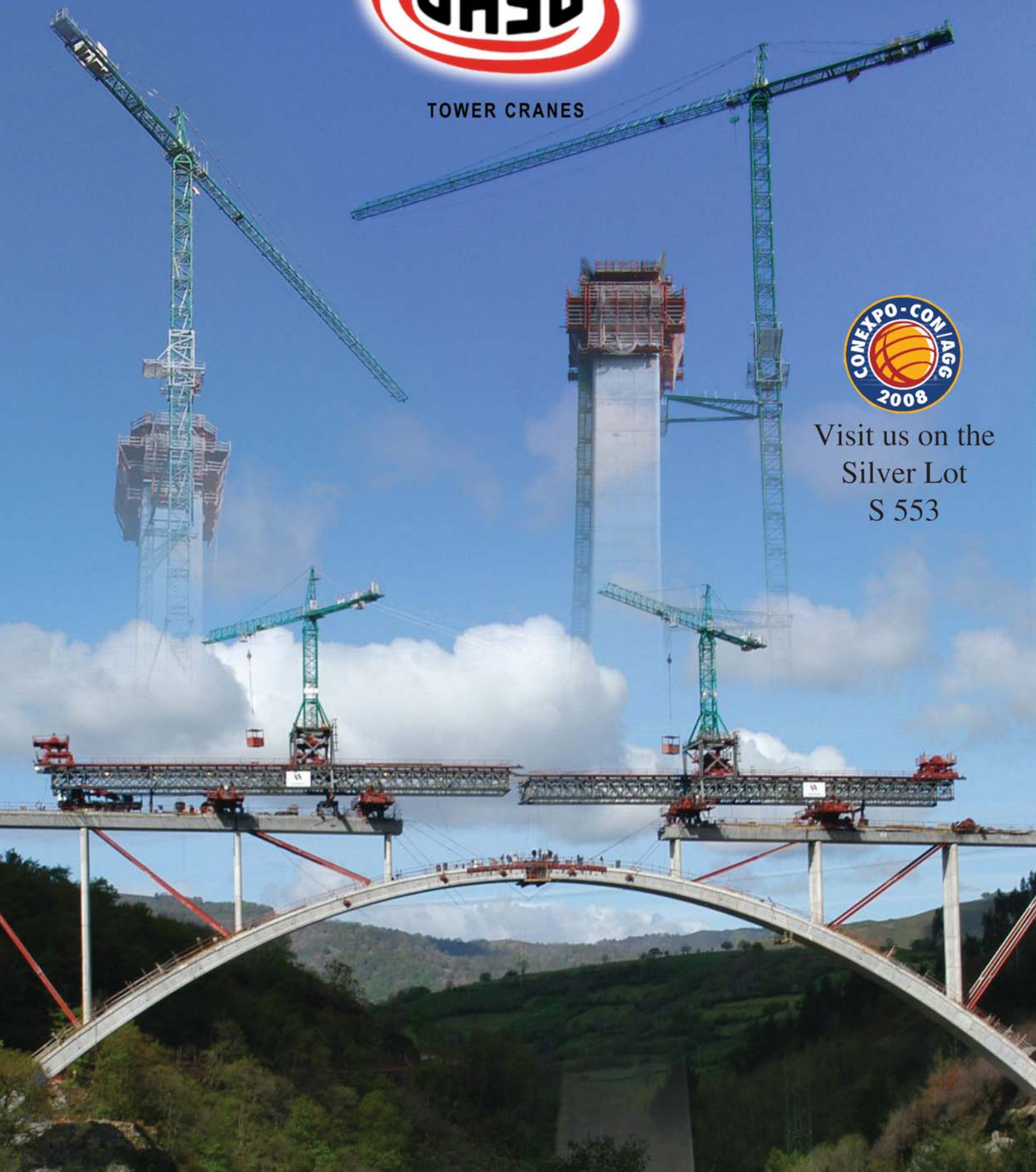



Since the last Conexpo in 2005 the number of tower cranes operating in the USA, not to mention the rest of the world, has mushroomed. You only have to take a drive - or a walk down the Las Vegas strip to see how commonplace tower cranes have become in the USA.

With the rapid increase in population there has sadly been a growth in the number accidents, some of them fatal. A number of high profile incidents in the past 18 months has made the subject of tower crane safety a highly politicised issue in a number of states as well as in the UK. Major contractors are coming under increasing pressure to ensure that the safest practices possible are adopted on their sites.

Given the importance and topicality of this subject, a number of organisations and companies with an interest in crane safety have joined to provide a short and free workshop on the subject at Conexpo. The lead sponsor is SMIE, a company that has pioneered tower crane safety systems, including anti collision devices and wind monitoring systems. Others supporting the conference include: The NCCO which runs North American crane operator certification programmes, Morrow Crane the largest and

longest established tower crane rental company in the USA, Paul Phillips chair of the CPA Tower Cranes Interest Group in the UK and Vertikal.Net which reports on the crane and lift industries around the world.

The conference will highlight the need for awareness of hazards when handling materials on site and how to manage tower crane utilization to increase productivity by reducing exposure to risks and accidents. Key speakers will be from across the industry. The two hour program will consider the current regulations and site safety in respect of tower cranes, the options available to make tower crane operation safer and innovations and the benefits they are bringing to the industry.



The workshop is entirely free and will be held in ConExpo-Con/Agg Room No: S233 at 9:30 am on Thursday March 13th. Pre registration is available on line at <http://towercranesafety.net>



Desde el ultimo Conexpo en 2005 el número de grúas torre operando en EE.UU., por no mencionar el resto del mundo, ha crecido enormemente. Sólo tiene que dar una vuelta por la calle principal de Las Vegas para dares cuenta lo común que se ha vuelto el ver grúas torre en Estados Unidos.

Con el rápido incremento de la población ha habido un aumento de los accidents, en muchos casos fatales. El número de graves incidents en los últimos 18 meses ha hecho que el tema de la seguridad en las grúas torre se convierta en un tema politizado en un gran número de Estados, así como en el Reino Unido. Los principales contratistas están bajo mucha presión para asegurar que se llevan a cabo las maores practicas seguras en el lugar de trabajo.

Con la importancia del tema, un número de organizaciones y empresas con intereses en la seguridad en las grúas torre se han unido para prporcionar un foro de trabajo de entrada libre durante la feria. El esponsorizador sera SMIE, una empresa pionera en sistemas de seguridad en grúas torre, incluyendo



la grúa torre para incrementar la productividad reduciendo la exposición a riesgos y accidents. Loa conferenciantes seran de esta industria. El programa de dos horas considerará la actual normative y la seguridad en grúas torre, las



dispositivos anti collision, y sistemas de monitorización de viento, etc... Otros que esponsorizan la conferencia son el NCCO, que se ocupa de las certificaciones de operarios de grúas torre en Norteamérica, Morrow Crane, una de las empresas de alquiler más grandes de EE.UU., Paul Philips, presidente de CPA Tower Cranes Interest Group en el Reino Unido y Vertikal.Net, que ofrece puntual

opciones disponibles para realizar un trabajo seguro y los beneficios que eso reportará a la industria.

Las conferencias son de entrada gratuita y se celebrarán ConExpo-Con/Agg Room No: S233 a las 9:30 am el jueves 13 de marzo. Se pueden registrar on line en: <http://towercranesafety.net>

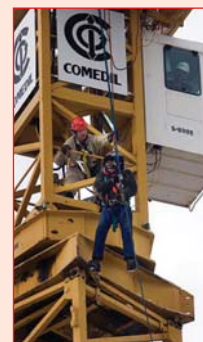

información de grúas en todo el mundo.

La conferencia tratará la necesidad de ser consciente de los riesgos cuando se manejan materiales y cómo manejar



CITY MAP

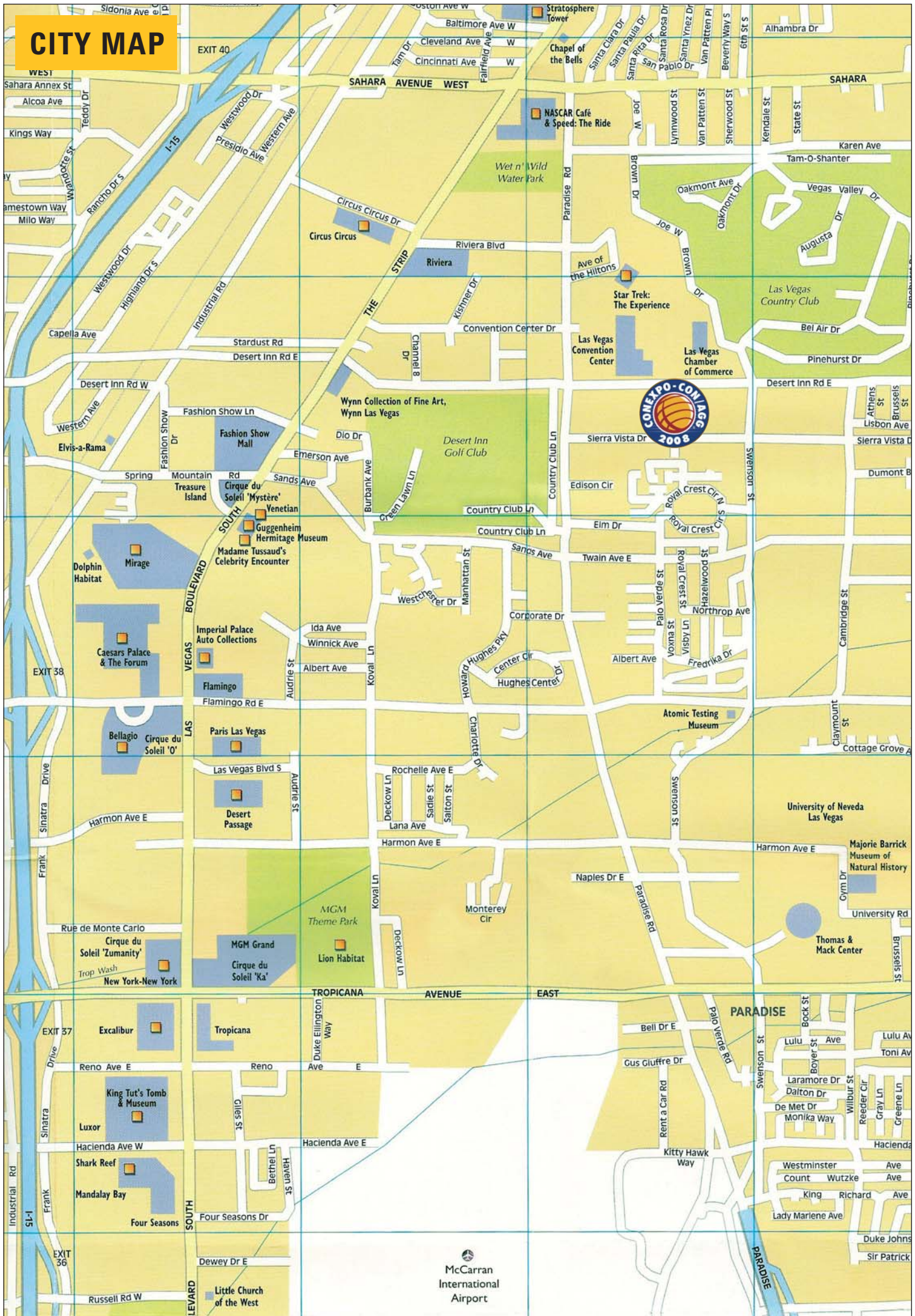

McCarran
International
Airport

Sights not to miss!

There are a great deal of things to see in Las Vegas and many of them are free, we like that! Here are just a few of them.

Construction sites. At the moment Las Vegas is one of North America's largest building sites with several massive developments underway most of them can be seen from the sidewalks on the Strip. Aside from this...

The fountains at Bellagio. More than a 1,000 fountains soar up to 240ft/73m as they perform a ballet to classic songs and music, every half hour in the afternoons and then every 15 minutes from 8pm till midnight. Inspiring!

The pirates and sirens battle at Treasure Island occurs every 90 minutes with a band of pirates battling it out with a bevy of buxom sirens, great pyrotechnics this one is a traffic stopper.

The Fremont street experience.

A few years ago the downtown street outside the

Golden Nugget was roofed in with millions of light bulbs fitted to the

inside to produce a jaw dropping light show with 540,000 watts of music that is jaw droppingly incredible - every hour on the hour after dark.

The original **Las Vegas Glitz Glitter Gulch** is the short narrow street incandescent with light bulbs and original neon!

The Shark Reef at Mandalay Bay, a visit is not cheap but well worth seeing this 1.3 million gallon/6 million litre tank with walkways through it.

The Lion habitat at MGM Grand a free attraction showing off its collection of big cats.

The show at Circus Circus has often included famous acts and changes every half hour till midnight.

The Mirage Volcano and waterfall, the volcano goes off every 15 minutes



at night spewing fire over 100ft/30m into the air as massive volumes of water tip over the edge.

M&M World, yes really, is an attraction that includes a 3-D movie at the MGM and it's free.

The View from the top of the **Stratosphere tower** an amazing view and if you are a little unbalanced there are also some crazy amusement rides.

The Forum shops at **Ceasars Palace,** with its sky ceiling and animated statues, a show is held every hour.

The Gondolas and minstrels at the Venetian not to mention the St Marks square where you seem to be outside.

The art collection at the Bellagio,

some of the worlds finest and most expensive pieces, a Monet exhibition is on this week, entrance fee is \$15.

The Musical artefact displays at the **Hard Rock hotel and casino.**

The world's largest gold nugget at where else?- the **Golden Nugget.**

The Strip at night try the view from the bar at the top of the Rio.

Paris, the Eifel tower might only be half size but the lights replicate those fitted for the 100th anniversary on the original tower and it was built to Gustave Eifels original drawings.



Cosas que no debe perserse!

Hay muchas cosas que ver en Las Vegas y muchas de ellas son gratis, eso nos gusta! Aquí están algunas de ellas.

Las construcciones, en este momento en Las Vegas sus construcciones son en sí mismas una atracción, que se puede ver desde ambos lados de la calle, pero además...

Las fuentes en el Bellagio, más de 1000 fuentes planean por 240ft/73m mientras realizan un ballet con canciones de música clásica, cada media hora por las tardes y cada 15 minutos a partir de las 8 :00 pm hasta media noche. Inspiador!

La batalla de piratas y sirenas en **Treasure Island** es cada 90 minutos con una banda de piratas en plena batalla contra

unas exuberantes sirenas, gran pirotécnia, es una parada muy concurrida.

La Calle Fremont

Hace años el downtown de la ciudad fuera del **Golden Nugget** estaba techado con millones de bombillas que te dejaban la boca abierta con 540,000 vatios de música - cada hora a partir de que se vaya el sol.

La ostentación de **Las Vegas Glitter Gulch** es la calle estrecha incandescente con bombillas y neón!



El Arrecife de tiburones (Shark Reef) en **Mandalay Bay,** una visita nada barata pero que merece la pena con su pecera de 1.3 millones de galones /6 millones de litros con pasillos para pasar por debajo.

El Habitat de Leones en el MGM Grand

una atracción libre que muestra sus felinos.

El espectáculo en el **Circus Circus** normalmente ha incluido números famosos y cambios cada media hora hasta media noche.

El Volcán del Mirage y la cascada, el volcán es cada 15 minutos por la noche echando fuego a 100 ft/30m mientras grandes cantidades de agua se caen sobre el filo.

M&M World, si de verdad, es una atracción que incluye una película en 3D en el MGM y es gratis.

La vista desde la **torre Stratosphere** es espectacular y si no le da miedo hay algunas atracciones encima de la torre.

Las Tiendas del Forum en el **Ceasars Palace,** con su cielo y estatuas animadas, con un espectáculo cada hora.

Las Gondolas y Trovadores en el **Venetian** por no mencionar la Plaza de San Marcos donde parece que estás a la intemperie.

La colección de arte del Bellagio, con

piezas muy caras, hay una exposición de Monet esta semana, por \$15 la entrada.

Todo sobre la Música en el **hotel y casino Hard Rock.**

La nuez más grande del mundo de oro donde estará? En el **Golden Nugget.**



El Strip (calle principal) de noche, pruebe la vista desde el bar en lo alto del Rio.

Paris, la torre Eifel puede que sea la mitad en tamaño que la original, pero la replica es exquisita y las luces se pusieron en su 100º aniversario y se construyó según los planos originales de Gustave Eifels.

MONORAIL MAP

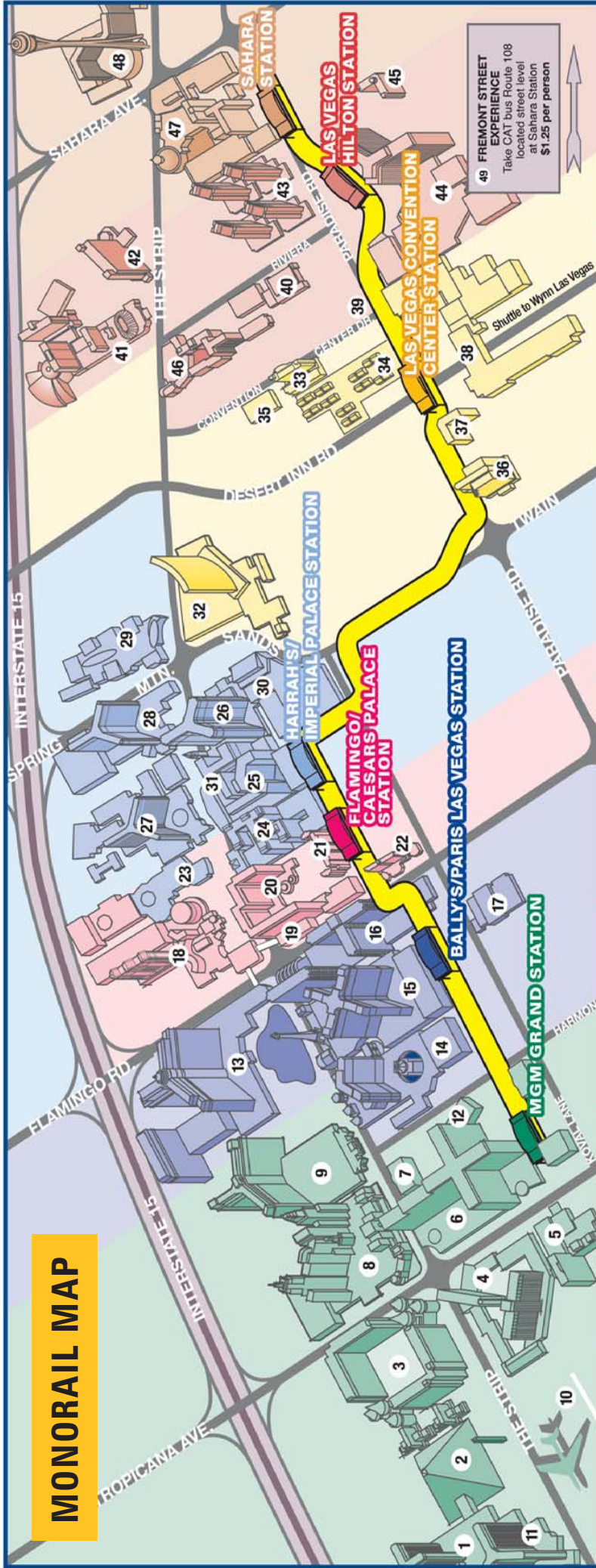

49 FREMONT STREET EXPERIENCE
Take CAT bus Route 108 located street level at Sahara Station \$1.25 per person

<p>MGM GRAND STATION</p> <p><i>Access to:</i></p> <ul style="list-style-type: none"> 1-Mandalay Bay Mandalay Bay Convention Center 2-Luxor 3-Excalibur 4-Tropicana 5-Hooters Casino Hotel 6-MGM Grand Fashion Outlets of Las Vegas Shoppers' Shuttle 7-Showcase Mall 8-New York-New York 9-Monte Carlo 10-McCarran Int'l Airport 11-Four Seasons 12-Marriott's Grand Chateau 	<p>BALLY'S/PARIS LAS VEGAS STATION</p> <p><i>Access to:</i></p> <ul style="list-style-type: none"> 13-Bellagio 14-Planet Hollywood Miracle Mile Shops at Planet Hollywood 15-Paris Las Vegas 16-Bally's Las Vegas 17-Ellis Island 	<p>FLAMINGO/CAESARS PALACE STATION</p> <p><i>Access to:</i></p> <ul style="list-style-type: none"> 18-Caesars Palace 19-Bill's Gamblin' Hall & Saloon 20-Flamingo Las Vegas 21-Hilton Grand Vacations 22-Westin Casuarina Battista's Hole in the Wall Restaurant 	<p>HARRAH'S/IMPERIAL PALACE STATION</p> <p><i>Access to:</i></p> <ul style="list-style-type: none"> 23-Forum Shops at Caesars 24-Imperial Palace Hotel & Casino 25-Harrah's Las Vegas Rio (via Harrah's Shuttle) 26-The Venetian/Grand Canal Shoppes 27-Mirage Las Vegas 28-TI (Treasure Island) 29-Fashion Show 30-Sands Expo 31-Casino Royale 	<p>LAS VEGAS CONVENTION CENTER STATION</p> <p><i>Access to:</i></p> <ul style="list-style-type: none"> 32-Wynn Las Vegas (via Wynn Shuttle, 8 a.m. - 8 p.m.) 33-Marriott-Residence Inn 34-Courtyard by Marriott 35-Greek Isles 36-Embassy Suites 37-Renaissance Las Vegas 38-Las Vegas Convention Center/Sprint Retail & Wireless Tech Lounge 39-Visitor Information Center 	<p>LAS VEGAS HILTON STATION</p> <p><i>Access to:</i></p> <ul style="list-style-type: none"> 40-Marriott Suites 41-Circus Circus Vacations (on Strip) 42-Hilton Grand (Stirling Club) 43-Turnberry Place (at Las Vegas Hilton) 44-Las Vegas Hilton 45-Hilton Grand Vacations (at Las Vegas Hilton) 46-Riviera 	<p>SAHARA STATION</p> <p><i>Access to:</i></p> <ul style="list-style-type: none"> 47-Sahara Hotel & Casino Sahara NASCAR Cafe 48-Stratosphere 49-Fremont Street Experience (via CAT bus Route 108) 
--	--	---	---	--	--	---

With rapid development of the city, traffic on the strip has become hugely congested at certain times of the day. This is exasperated by very long traffic lights at all major intersections. It can take as long as 50 minutes to go from one end of the strip to the other during peak times.

Shuttle Bus

Conexpo has organised a free shuttle bus service between the convention centre and most major hotels during the show.

Taxi cab

Taxi cabs are generally only available from the front of hotels. You can hail one in the street, but

will not get on the bus unless you do. The service is hugely popular and even though there are buses every few minutes, they are invariably packed at peak times - perhaps not during Conexpo when fewer bus type people are in town? It is also subject to vagaries of Strip traffic so can be slower than walking.



succeeding at this during a busy show week is about as rare as flying pigs.

Taxis tend to avoid using the strip due to the traffic and take alternative roads, this can make the trip seem very circuitous, it does not necessarily mean your driver is scalping you, it is almost always faster. All cabs have meters and charge a fixed fee of \$3.20 plus \$2 a mile or 25 cents a minute when stationary. Las Vegas drivers expect a decent tip and can get nasty if you only give them a few cents. A couple of dollars on a \$10 to \$15 charge usually avoids insults.

When everyone is heading out for the evening you can be subjected to a long wait in line, here are some alternatives:

Take the bus

The Deuce is a double deck bus that runs up and down the strip all day, the cost is \$2 for a single or \$5 for an all day pass. You must though have the exact change, you

Go with the Monorail

This is fast and predictable taking 18 minutes in total to run from one end of the strip to the other.

However it only runs on one side of the strip, behind the big hotels like Ballys and MGM, so getting to a station from hotels on the opposite side can be a long walk. If you are going to or from the show a general rule of thumb is that the further you are away from the convention centre the more attractive a proposition it is.

The Monorail operates from 7 a.m. to 2 a.m. (3 a.m. on weekends) A Single-ride fare is \$5. A two-ride ticket, \$9, a 10-ride ticket \$35. A 24 hour unlimited pass is \$15. A three-day unlimited pass- \$40. Special deals and discounts are also often available. Conexpo has negotiated a 20% discount and a \$9 rate for the 24 hour unlimited ticket if bought before the end of February - they may have extended it so do mention Conexpo at the ticket booth.



Con un desarrollo rápido de la ciudad, los atascos en la calle principal son un engorro a ciertas horas del día. Es consecuencia de la cantidad de semáforos que hay en cada esquina. Puede llevarle hasta 50 minutos cruzar de una punta a la otra del strip (calle principal)

Transporte en autobus

Conexpo ha organizado un servicio gratuito de autobuses entre la feria y la mayoría de los principales hoteles.



Taxis

Los taxis están generalmente solo disponibles en los hoteles principales, puede intentar parar alguno desde la calle, pero sera casi una misión imposible.

Los taxis tienden a evitar la calle principal y tomar calles alternativas, no crea que le están engañando, sino que esto es muchas veces la alternativa más rápida. Todos los taxis cuentan con taxímetro y cobran fijo \$3.20 más \$2 por milla o 25 centavos el minuto si está parado. Los taxistas de Las Vegas normalmente esperan buenas propinas y no se lo toman muy bien si solo se les da unos centavos. Evitará malas caras si en una carrera de \$10 a \$15 les da dos dólares.

Cuando cae la tarde y todo el mundo tiene prisa por llegar a sus citas, algunas alternativas son estas:

Coger el autobús - El Deuce es un autobus de dos plantas que funciona por toda la calle principal durante todo el día, el coste son \$2 un billete o \$5 un billete para todo el día. Debe llevar cambio exacto, si no, no le darán cambio. Hay mucho flujo de autobuses, aunque en horas puntas van bastante llenos. Teniendo el tráfico, habrá veces que llegue antes andando que en autobus.

Ir en Monorail: Una forma rápida de llegar de una punta a otra de la calle principal, en solo 18 minutos. Pero solo va por un lado de los hoteles, como el Ballys y MGM.

El Monorail opera desde las 7.00 a.m. hasta las 2 a.m. (3 a.m. en fines de semana). Un billete de ida son \$5. Un billete de dos viajes son \$9, y 10 viajes son \$35. Hay un billete de 24 horas que cuesta \$15. Un billete para tres días son \$40. Hay disponibles otras ofertas. Conexpo ha negociado un 20% de descuento y se puede adquirir un billete de 24 horas por \$9 si se compra antes de finales de febrero - aunque siempre lo puede mencionar cuando vaya a adquirir su billete.



Restaurants and Bars a Vertikal Guide

Here is our selection of places to eat and hang out. The selection is entirely arbitrary, ones we have tried or those influenced by friends, locals and just because they took our fancy...

Choice you certainly have in Las Vegas, from the very finest haute cuisine (yes really) to the most mind bogglingly amazing buffets to highly themed novelty restaurants where the food is almost an afterthought and everything in between. Be warned that during Conexpo the better places will be tough to get into and even if you do reserve, after 8:00 be prepared, at least in the mid range restaurants, for your table not to be available until well after the time you reserved; Sounds like the crane business!.

Andrés

One of the longest established restaurants in Las Vegas having opened in 1980. The Original Andrés is still an excellent French restaurant. Pricy but good and located in a quiet neighbourhood. The 1930's building has Private rooms that can be reserved.
401 South Sixth Street Tel: 385-5016

Aureole

If you are a wine buff this might be just the place for you, the restaurant is built around a four storey glass wine storage tower. The wine list is a computer tablet, allowing to search by country, grape variety or whatever, with some 800 cabernets for example, it is a bit of gimmick and expensive. The food is good by not great, the prix fixe menu is \$75 with supplements but if you are out to impress??
Mandalay Bay: Tel:632-7401



Bouchon

A fantastic bistro, with excellent seafood, lamb and other dishes, in a great setting you might try and get a table on the outside terrace although they are in high demand. Given the quality this restaurant offers excellent value.
The Venetian: Tel: 414-6200

Craftsteak

A clone of the famous New York eatery, if you are looking for grilled meat this is the place to come. Simple good quality food and decor, some of the best steaks in town, with more exotic fare, such as Kobe beef tartare, quail or sweatbreads also on the menu.
MGM Grand Studio Walk: Tel:891-7318.

Joes Seafood Steak & Stone Crab

A noisy popular restaurant whose name says exactly what it does. You will need to book but it is worth it. If you order its 'signature steak' the 22 ounce Porterhouse we suggest you share it with someone. If you never had fried green tomatoes this is the place.
Forum at Caesars Palace: Tel: 792-9222.

Koto

If you are a Japanese food lover or just enjoy good sushi then this might be a place for you? Located in a strip mall it is not the most elegant restaurant in town, but quality is excellent and you will find Japanese dishes here that you will not find elsewhere.
9400 South East Ave-Henderson Tel:221-1600

Pamplemousse

Another long established country French restaurant! Less expensive and and some say slipping a bit, There is no written menu here, you start with a big basket of fresh crudités and then the waiter will tell you what they are cooking as it changes depending on what is good at the market. Don't worry you will still be spoilt for choice.
400 E.Sahara Ave Tel:733-2066.

PF Changs

Another chain but this Chinese/Thai restaurant has a great atmosphere good food and a modest price. But a word of warning it is constantly crowded and you may have to wait. There are three in town we tried the one on Paradise Avenue.
4165 Paradise Rd Tel: 792-2207

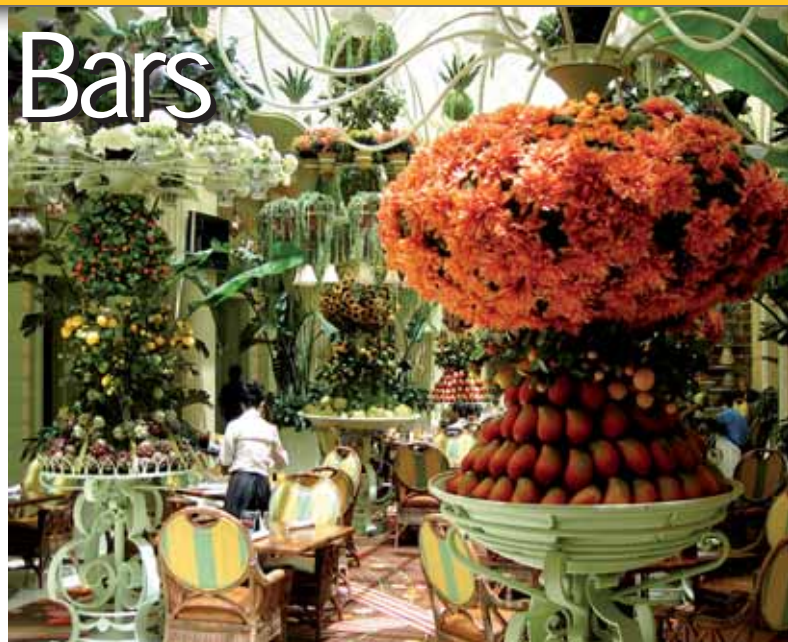

Redwood Bar and Grill

If you are looking for a great piece of beef and good value then you can do a lot worse than ask for 'the porterhouse special' at the Redwood, it is not on the menu but they will know what you want. Meals come with soup or salad and vegetables all for around \$20. This is downtown, a good place to eat if you want to explore the downtown area one evening
The Californial: Tel: 385-1222.

Tableau

Tableau serves American/Mediteranean food in a beautiful French inspired dining room, if the terrace is open this would be our choice for a overlooking one of the pools. The food is excellent and given its quality reasonable value and good service.
The Wynn: Tel:248-3463

The Hofbrauhaus

Is this a hang over from Vertikal Bauma? While risking the derision of those German readers who consider the original Hofbrauhaus in Munich is tacky enough, The beer and some of the food is shipped in from Bavaria, so if you are desperate for a good German beer this might be the place to go. It is off the strip but they have a free shuttle.

Ventano

We had to have a proper Italian! The Ventano is a rustic Italian in Henderson with a fantastic view from its wraparound terrace with views of the mountains. Lively and friendly and unpretentious good value. **191 Arroyo Grande, Henderson Tel: 944-4848**

Voo Doo Steak

Located at the top of the Rio tower New Orleans cuisine including crawfish and Blue crab cakes. Excellent bar as well and you can see the whole city from up here. **Rio Hotel: Tel: 777-7923**

Wolfgang Puck

Yes another chain!! But we hear that this is one of the best and great value, California cuisine wide range of dishes from steaks to sausages, calf livers and more. **MGM Grand: Tel: 891-3000**

Buffets

If Buffets are your scene then Las Vegas is your heaven. We hear that the following are among the best:

The Planet Hollywood spice market and the Rio Carnival World Buffets, And as you might expect the Wynn and Bellagio buffets consistently rate among the best. Le Village at Paris has stations representing different regions of France and is also said to be very good...If you like buffets that is.



Bars

We didn't leave much space for Bars, the Ghost bar at the Palms is supposedly the place of the moment and has great views, then the House of Blues in the Mandalay Bay always rates highly, a restaurant by day a nightclub by night, it is apparently somewhere not to miss. If you are looking for a throwback to the Las Vegas of the 1970's try the Casbar Lounge in the Sahara and of course the top of the Rio.

Restaurantes y Bares

Una Guía de Vertikal

Aquí está nuestra selección de lugares para comer y salir, la selección es totalmente arbitraria, unos que ya hemos probado y otros recomendados por amigos, horiundos y porque tienen Buena pinta...

Desde luego tiene donde elegir en Las Vegas, desde la alta cocina (de verdad) o los más impresionantes buffets hasta los nuevos restaurantes temáticos donde la comida es lo de menos. Tenga en cuenta que durante la feria de Conexpo los mejores sitios estarán llenos e incluso reservando, después de las 8:00 prepárese, al menos en los restaurantes de gama media, para esperar un buen rato su mesa; suena como el negocio de las grúas!

Andrés

Uno de los restaurantes con más solera de Las Vegas. Abrió en 1980, el Andrés original es todavía un restaurante francés excelente. Algo caro pero bueno y situado en un barrio tranquilo. El edificio de 1930 cuenta con reservados. **401 South Sixth Street Tel: 385-5016**

Aureole

Si Ud. es aficionado al vino este puede ser su lugar, el restaurante se ha construido alrededor de una torre de almacenaje de vino de 4 pisos de cristal. La carta de vinos es una carta computerizada, permitiendo buscar por países, variedad de uva o lo que sea, con más de 800 cabernets por ejemplo, es un poco un truco de promoción y caro. La comida es buena pero no excelente, el precio del menú es fijo de \$75 con suplementos pero si está fuera para impresionar??

Mandalay Bay: Tel:632-7401

Bouchon

Un fantástico bistro, con excelente marisco, cordero y otros platos, en un gran ambiente puede que consiga una mesa en la terraza de fuera aunque siempre están muy demandadas. De gran calidad, este restaurante ofrece un excelente valor.

The Venetian: Tel: 414-6200

Craftsteak

Un clon del famoso sitio en Nueva Cork, si busca carne a la parrilla este es el lugar al que tiene que ir, buena calidad de comida y buena decoración, hacen unos de los mejores chuletones en la ciudad, con cosas exóticas en la carta, como el tartar de carne de vaca de Kobe, codorniz o mollejas. **MGM Grand Studio Walk: Tel:891-7318.**

Joes Seafood Steak & Stone Crab

Un ruidoso restaurante popular cuyo nombre dice exactamente lo que ofrecen, carne, marisco y cangrejo. Necesita reservar pero merece la pena. Si pide su 'signature steak' de 22 onzas, le sugerimos que lo comparta. Si nunca ha probado los tomates verdes fritos, hágalo aquí. **Forum en el Caesars Palace: Tel: 792-9222.**

Koto

Si le encanta la comida japonesa o le gusta el buen sushi entonces este es su lugar. Situado en un centro comercial de la calle principal, no es el restaurante más elegante de la ciudad, pero la calidad es excelente y encontrará platos japoneses que no encontrará en ningún otro sitio. **9400 South East Ave-Henderson Tel:221-1600**

Pamplemousse

Otro restaurante francés de gran solera! Menos caro y según algunos ha decaído un poco. No hay carta impresa, se comienza con una gran cesta de crudités y después el camarero le informará sobre lo que están cocinando, ya que depende de lo que sea bueno ese día en el mercado. No se preocupe, tendrá muchas posibilidades.

400 E.Sahara Ave Tel:733-2066.



PF Changs

Otra cadena, pero tipo Chino/Thai, con gran ambiente, buena comida y un precio razonable. Sólo una cosa, está siempre lleno, a lo mejor tendrá que esperar. Hay tres en la ciudad, nosotros probamos el de la Avenida Paraíso. **4165 Paradise Rd Tel: 792-2207**

Redwood Bar and Grill

Si busca un buen trozo de buey de calidad puede pedir 'the porterhouse special' en el Redwood, no está en el menú pero sabrán lo que les pide. Las comidas vienen con sopa o ensalada y vegetales, todo por \$20. Está en el centro de la ciudad, por si quiere explorar esa zona de noche.

The Californial: Tel: 385-1222.

Tableau

Tableau sirven comida tipo Americana/mediterránea en unos salones con inspiración francesa. Si la terraza está abierta debería probarla, para echarle un vistazo a las piscinas. La comida es excelente, de calidad y buen servicio.

The Wynn: Tel:248-3463

The Hofbrauhaus

Es la resaca de Bauma? A riesgo de la irrisión de aquellos lectores alemanes que consideran el Hofbrauhaus original de Munich un poco hortera, la cerveza y alguna comida traen de Bavaria, por lo que si está desesperado por una buena cerveza alemana este es su sitio. Está fuera de la calle principal, pero ofrecen traslado gratis.

Ventano

Teníamos que incluir un italiano apropiado! El Ventano es un italiano rústico en Henderson con una vista excelente desde su terraza con vistas a las montañas. Muy vivo y acogedor, con comida nada pretenciosa. **191 Arroyo Grande, Henderson Tel: 944-4848**

Voo Doo Steak

Situado en la torre Rio ofrecen comida de Nueva Orleans incluyendo cangrejos de río y pasteles de cangrejo. Un bar excelente, además de poder ver la ciudad desde arriba. **Rio Hotel: Tel: 777-7923**

Wolfgang Puck

Otra cadena!! Pero hemos oído que es la mejor, comida de California con una gran cantidad de platos desde carne, carne de ternero, etc.

MGM Grand: Tel: 891-3000

Buffets

Si le encantan los buffets, entonces Las Vegas para Ud. es el cielo. Nos han contado que los siguientes son los mejores:

Los buffets de **Planet Hollywood spice market** y del **Rio Carnival World Buffets**. Y los del **Wynn** y el **Bellagio** también son excelentes. **Le Village at Paris** tiene estaciones que representan diferentes regiones de Francia y dicen que es muy bueno. Si es que le gustan los buffets.



Bares

No hemos dejado mucho espacio para los bares, el **Ghost bar** en **Palms** se supone que es el sitio de moda y tiene grandes vistas. Y el **House of Blues** en el hotel **Mandalay Bay** siempre está de moda, un restaurante de día y sitio de copas de noche, por lo que no hay que perderse. Si Ud. busca una vuelata a Las Vegas de los 70, vaya a **Casbar Lounge** en el **Sahara** y por supuesto la parte de arriba del **Rio**.



Take in a Show

Las Vegas has bigger, flashier and more shows than anywhere else on earth, by a wide margin. Some of the shows are so spectacular and expensive to stage, that they could only happen here.

There are way too many to list them all here, so we feature a few that we know to be good, unique or popular. Tickets can be purchased at a desk in your hotel, they are also available online and for the miserly there are agencies that sell half-price tickets from midday for that evenings performance. However don't expect to find too many cut price tickets for top line shows, especially this week when over 140,000 visitors are in town. Our favourites are those by **Cirque de Soleil**, which currently has five different

magic of the theatre, from the simplest street performance to the most lavish opera and the theatre of life. **KÀ** at the MGM Grand has an amazing and menacing set with an amazing gantry set up. It combines martial arts, puppetry, multimedia and pyrotechnics to the story of separated twins who embark on a journey to fulfill their destinies - more of a story than the other shows. **Zumanity** at New York, New York, is a sensual and erotic show - not pornographic just sexually suggestive. The latest show from the Cirque de



shows in town. The longest running is **Mystère** at Treasure Island a combination of odd ball humour and incredible acrobatic acts, it is possibly still their best. "O" at Bellagio is an equally amazing show featuring lots of water (eau) it pays homage to the



Soleil is **Love**, which includes lots of Beatles music, incredible video effects and an amazing sound track - more rooted in real life it is an amazing extravaganza. Much more down to earth is **Rita Rudner**, she's an excellent stand up comedienne and one of the few to have made it on both sides of the

Atlantic. If you wanted to see **Elton John** and the Red Piano - he is in Florida this week, if you are staying on in Las Vegas though he is back on the 19th. **Bette Midler**, alternates with him at the Caesars Palace Colliseum, the hotel has a special dinner and show package which is worth a look. For **Monty Python** fans, **Spamalot** is in town at the Wynn and winning great acclaim. If you don't get Monty Python then give this one a wide berth. The **Blue Man group** with its three bald blue men is off-the-wall and zany, definitely not for the up-tight! If you don't want

to be dragged into the act don't sit at the front.

Mamma Mia is still highly popular and for women of a certain age, **Menopause** will have you rolling in the aisles. For a full guide to the hundreds of shows you will find free guides around the hotel.



de dos gemelos separados que se embarcan en un viaje para cumplir sus destinos, cuenta una historia más que los otros espectáculos. **Zumanity** en el New York, New York, es un espectáculo sensual y erótico - no pornográfico sino sexualmente sugerente. El último espectáculo del Circo del Sol es **Love**, que incluye música de los Vétales, efectos de video y una banda sonora impresionante - es una extravagancia.

Mucho más cercano a la tierra se encuentra **Rita Rudner**, una excelente comedianta que ha triunfado a ambos lados del Atlántico. Si quería ver a **Elton John** and the Red Piano - estará en Florida esta semana, si se queda en las Vegas, vuelve el 19. **Bette Midler**, se turna con él en el Caesars Palace Colliseum, el hotel tiene una cena especial y entradas, merece la pena verlo.

Para los fans de los **Monty Python**, **Spamalot** está en la ciudad en el Wynn con gran éxito. Los **Blue Man group** es un grupo de tres hombres de azul, un tanto estrafalario, si no se quiere marchar no se coloque delante!

Mamma Mia es todavía muy popular para mujeres de cierta edad, **Menopause** le hará bailar por los pasillos. Para conseguir información de los cientos de espectáculos encontrará guías en los hoteles.



Disfrute de un espectáculo

Las Vegas cuenta con los mayores espectáculos de todo el mundo, con creces. Algunos espectáculos son increíbles y caros, pero solo se pueden ver aquí.

Hay tantos espectáculos que hemos elegido algunos para recomendar, ya sea por que son Buenos, únicos o los más conocidos. Las entradas se pueden comprar en la recepción de su hotel, también los puede conseguir por Internet o hay agencias que venden entradas a mitad de precio a partir del mediodía para los espectáculos de esa noche. Sin embargo, no espere encontrar muchas gangas de este tipo, especialmente en semana de feria, que puede haber hasta 140,000 visitantes en la ciudad.

Nuestros favoritos son los del **Circo del Sol**, que actualmente tiene cinco espectáculos en cartel. El que lleva más tiempo es **Mystère** en Treasure Island, una combinación de humor e increíbles acrobacias, es posible que sea el mejor. "O" en el Bellagio es igualmente un espectáculo increíble con mucho agua (eau), desde las representaciones callejeras a la ópera más prodigiosa. **KÀ** en el MGM Grand tiene un gran montaje escénico, combina artes marciales, marionetas, multimedia y pirotécnica para contar la historia

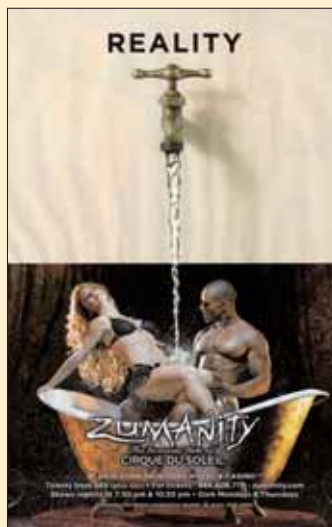

It is Gaming not Gambling



Apparently the word gambling, is not considered to be "elegant" in Nevada - the word is Gaming! Well Gambling, Gaming, Tomato, Tomayto the game is the same and this is the world capital of it.

What though, are your chances of leaving Las Vegas with money in your pocket? It all depends on what game you play and how well you know the game. One game where the odds are surprisingly in your favour is **Craps**, especially if you know what you are doing. The same applies of course to **Poker**, which has become lot more popular in recent years.

Blackjack is easier to understand than craps and offers the best odds, which is why it's so popular in Las Vegas. Success though depends on how well you can assess your chances and then make a decision, if you are weak and "wishy-washy" the odds jump in favour of the casino. Confidence and a quick mind are the key as is quitting when you are ahead and coming back later.

Roulette is the easiest to play but Europeans note that over here we have two zeros, which significantly increases the Casinos odds, only play this game for fun, the odds are stacked in the casinos favour which is why it's less popular.

Keno is a local speciality, introduced by Chinese 'coolies' working on the railways, you can play this almost anywhere in the hotel, thanks to the Keno runners who will take your bets no matter where you are! Keno is a form of lottery, and the odds of winning are poor, easy and fun but don't

expect to break the bank.

Then of course we have **Slots!** The fact that most of the casinos' income comes from these machines should tell you everything. The problem with slots is that it is easy to get carried away and most people simply put all their winnings right back in! But the fun is to see how long you can last and people do walk away with big jackpots, just not many of them.

One thought that might cheer you, the casino will provide **free drinks** while you play. So as long as you don't play too fast and furious, you can save seven dollars or more a cocktail! So not all of what you are feeding into the machine is a loss! Most casinos have **Slots clubs**, if you are going to play frequently join one, you'll get a card and can rack up benefits and obtain discounts even before you play.

So if you are taking your gaming seriously...Blackjack and Craps are the games to go for. All casinos offer free lessons each morning. Take them up on it, the dealers will teach you how to win and not only will you enjoy it more but you might also stand a chance of going home with some money in your pocket! I did say **might!**



Es jugar, no apostar

Aparentemente el mundo de las apuestas no se considera elegante en Nevada, la palabra que hay que utilizar es juego! Ya sea apostar, jugar, Tomate o Tomayto, el juego es el mismo y esta es su capital.

Sin embargo, ¿cuáles son sus posibilidades de salir andando habiendo ganado en un casino en Las Vegas? Depende de los juegos que juegue y lo bien que lo conozca. Uno de los juegos donde los astros están a su favor son los **Dados**, eso a menos que sepa lo que hace.

Lo mismo se puede aplicar al **Blackjack**, que cada vez es más popular. Por otro lado es más fácil de entender y puede tener suerte, por eso es tan popular en Las Vegas, el éxito depende de cómo juegue la partida, si toma una decisión pero duda, la suerte juega a favor del casino. La clave

es confianza y juego rápido.

La **ruleta** es todavía más fácil de jugar pero si procede de Europa, no olvide que se juegan con dos ceros, lo que aumenta las posibilidades del Casino, juegue a este juego solo para divertirse, porque normalmente la banca siempre gana.

Keno es una especialidad local, se puede jugar en prácticamente cualquier parte del hotel, ya que los que admiten apuestas de Keno están por todas partes! Keno es una especie de lotería, y las posibilidades deganar son muy reducidas, muydivertido, pero no espere arruinara la banca.

Tenemos por supuesto las **máquinas tragaperras!** El hecho de que la mayoría de los ingresos de los casinos provengan de las máquinas tragaperras significa algo, el problema es que es aditivo y la mayoría de la gente invierte lo que ha ganado por el hecho de

Game -Juego	Casino advantage -Ventajas del Casino
Baccarat	1.17% on bank bets - 1.36% on player bets
Blackjack	0.5% to 5.9% for most games
Craps	1.4% to 17% depending on the bet
Keno	20 to 35%
Roulette	5.6% to 7.89% depending on the bet
Slots - Tragaperras	2% to 25% (average 4% to 15%)
Video Poker	1% to 12% (average 4% to 8%)
Wheel of Fortune	11% to 24%

ver cuánto aguanta, es cierto que se ve gente que gana, pero no mucha.

El hecho de que mientras estás jugando el casino te invita a las bebidas es una ventaja, sólo hay que pensar que te estás ahorrando unos siete dólares por cocktail! no está perdiendo del todo! La mayoría de los Casinos cuentan con Slots Clubs, si va a jugar mucho, hagase socio de uno, obtendrá una tarjeta que refleja las ganancias y tendrá descuentos incluso antes de jugar.

Si se toma el juego en serio, sus mejores apuestas son Blackjack y los Dados, ya que los casinos ofrecen tutorias para todos los niveles cada mañana, atienda a esas clases y sus posibilidades de ganar aumentarán y podrá volver a lo mejor a casa con algo de dinero, pero sólo a lo mejor!



Time for Golf?

The Golf enthusiasts among you will not need any encouragement, with great weather and some superb courses most of which are open to the public. Our Golf expert has recommended the following ones first hand.



Las Vegas Paiute - Owned and operated by the Paiute native Americans. Three Great courses with open fairways, lush conditions, and a beautiful views of the desert mountains. Outside the city it is worth the drive. Tel:658-1400 or 888-921-2833

TPC Canyons - A beautiful desert course with challenging elevation changes. Home of the Las Vegas Invitational - a PGA tour stop and the place where Tiger Woods won his first professional PGA tournament. Tel: 256-2000.

Bears Best - A recreated collection of the best holes of Jack Nicklaus courses around the world. A unique experience with excellent service. Tel: 385-8500

Desert Pines - Only 15 minutes from the Strip we are told that it is a fun course requiring precise irons. With over 4,000 pine trees you can imagine why! Tel: 450-8000 or 888-397-2499

Badlands - Designed by Johnny Miller and Chi Chi Rodriguez as three nine hole courses, our expert says it is a 'neat course tucked between casinos off the strip. A few tricky holes with water and desert hazards'. Tel: 382-4653 or 800-468-7918.



Your concierge may recommend **Stallion Mountain** - thanks to its friendly arrangements with them.



We hear that it is overpriced, overplayed and poorly maintained. With three courses it does have a good layout.

Other courses that we hear are good:

Reflection Bay - Said to be one of the best in town. A par 72 course on the shore of a man-made lake, designed by Jack Nicklaus Tel:740-4653

Bali Hai - Located near the south end of the strip, with plenty of water features... watch out for palms and tropical plants. Tel: 450-8000 or 888-397-2499.

Las Vegas National - A par 71 course which has hosted LPGA and PGA tour events. With a well lit driving range for those of you who are tied to the stand all day. Tel:796-0013

Revere at Anthem - The course winds through three desert canyons with natural changes of elevation and fantastic views of the Las Vegas Skyline. Tel:259-4653

For the frugal
Call **Stand by Golf** on 866-711-2665

to buy unsold tee-off times at discounts or between 30 and 50% or go online www.standbygolf.com Las Vegas Golf Club the first in town built in 1939 it is a bargain at \$49 after midday Tel:646-3003

Black Mountain - 20 minutes out of town - \$75 a round it is a tough course and one of the few that will allow you to walk rather than use a cart.

And finally... for the few:
Shadow Creek apparently the most expensive course in the USA, and reserved for well heeled guests of MGM group hotels - Bellagio, Mirage, Treasure Island, New York, MGM, Luxor, Excalibur and Mandalay Bay.

Cascata apparently the most expensive course construction ever, fees are \$500 but it is a stunning experience. Tel:294-2000



campo difícil y uno de los pocos donde le dejarán caminar en vez de ir en carrito.

Y finalmente...para unos pocos:
Shadow Creek aparentemente uno de los campos más caros de EE.UU., y reservado para invitados importantes del grupo de hoteles MGM -Bellagio, Mirage, Treasure Island, New York, MGM, Luxor, Excalibur y Mandalay Bay.

Cascata aparentemente el campo más caro en su construcción, con precios de \$500, pero es una experiencia única. Tel:294-2000.



Tiempo para jugar al Golf?

Estoy segura que aquellos entusiastas del golf no necesitarán mucho esfuerzo en jugar, con buen tiempo y algunos super campos muchos de los cuáles están abiertos la mayoría al público. Nuestro experto en golf ha hecho un estudio de algunos campos, qué sacrificio! Y recomienda los siguientes.

Las Vegas Paiute - Operado y perteneciente a los nativos americanos Paiute. Tres grandes campos. Con calles abiertas, condiciones suntuosas y preciosas vistas de las montañas del desierto. Fuera de la ciudad es mejor conducir. Tel: 658-1400 or 888-921-2833

TPC Canyons - Un campo en el desierto muy bonito con cambios y elevaciones. Hogar de Las Vegas Invitational - una parada del tour del PGA y el lugar donde Tigre Woods ganó su primer torneo PGA profesional. Tel: 256-2000.

Bears Best - Una colección de los mejores hoyos de los campos de

Jack Nicklaus de todo el mundo. Una experiencia única con excelente servicio. Tel: 385-8500

Desert Pines - A sólo 15 minutos de la calle principal de Las Vegas nos han dicho que es un campo "divertido" que requiere hierros precisos. Con más de 4000 pinos ya se puede imaginar por qué! Tel: 450-8000 or 888-397-2499

Badlands - Diseñado por Johnny Miller y Chi Chi Rodríguez como tres campos de nueve hoyos, nuestro experto asegura que es un campo bien cuidado entre casinos. Algunos hoyos engañosos con agua y obstáculos del desierto. Tel: 382-4653 or 800-468-7918.

Su conserje quizás le recomiende **Stallion Mountain** - gracias a sus sus convenios con ellos, pero hemos oído que esta sobre precio, muy concurrido y mal mantenido. Con campos de árboles tiene un buen trazado.

Otros campos que hemos oído que son buenos:

Reflection Bay, dice ser uno de los

mejores en la ciudad, un campo de par 72, con un lago diseñado por Jack Nicklaus. Tel:740-4653

Bali Hai: Localizado en la parte sur de la calle principal, con mucho agua... cuidado con las palmeras y plantas tropicales. Tel: 450-8000 or 888-397-2499.

Las Vegas National Un campo de par 72 que ha acogido campeonatos de LPGA y PGA, con luz, muy bueno para aquellos que tienen que estar todo el día en el stand. Tel:796-0013

Revere at Anthem
El campo se extiende a través de tres cañones del desierto con cambios naturales de nivel y una vista fantástica del Skyline de Las Vegas. Tel:259-4653

Para frugal
Llame a **Stand by Golf** al 866-711-2665 para encargar las salidas y descuentos entre 30 y 50% o visite www.standbygolf.com

Las Vegas Golf Club, el primero en la ciudad construido en 1939 es un chollo a \$49 después del mediodía. Tel:646-3003

Black Mountain - A 20 minutos de la ciudad - \$75 aunque es un

The ultimate aerial lift!

Taking a helicopter ride into the Grand Canyon is perhaps the ultimate lift. It has to be among the best ways to experience this magnificent landscape - one of the Seven Wonders of the World.

Our design team Chris, Brett and Danny took the helicopter ride to see the Grand Canyon for the very first time in February. First impressions are everything so when asked for theirs, the response was full on - 'breathtaking, fantastic, amazing to be there, stunned by the silence on the canyon floor and above all... nothing really to do but take it all in'. So if you are debating what to do with any spare time in Las Vegas, a helicopter ride sounds just the ticket.

The trips are generally well organised and very easy to book through a host of locally based Las Vegas companies who can be contacted either through your hotel concierge, the internet or by simply using the golden pages. As you might imagine, the cost of flights will vary according to the length of the trip and the amount of time you spend on the Canyon floor.

Sundance Helicopters for example runs four trips a day, two in the morning, one over lunch and one early evening. For \$299 (plus \$23 fuel surcharge) you can get a three and a half hour trip which starts with a stretch limo pick-up at your hotel, a brief safety video at the airport and then a fabulous ride over Lake Mead, the Hoover Dam and the Grand Canyon with 45 minutes on the Canyon floor and a champagne lunch (albeit it basic) thrown in! The return journey takes in the entire Strip passing over the Stratosphere Tower. For an extra \$60 you can buy a

Flying over Lake Mead. Each passenger wears headphones to listen to a commentary and ask the pilot questions.



Aterrizando en el Cañón (I-D) - Brett, Danny y Chris

Landing on the canyon floor (L-R) - Brett, Danny and Chris.

DVD of your trip which is posted to your home address and souvenirs are available to buy from the airport shop.

Some facts on the Grand Canyon. One of the Seven Wonders of the World it is:

- Over two billion years old
- A mile (1.6km) deep and 10 miles (16km) wide
- Habitation dates back 4,000 years
- Helicopter companies are required to pay \$1million a year to the Indian Reservation for the privilege of landing
- Information and bookings for all types of visits to the canyon can be made through www.xanterra.com or call 888-297-2757

Other day trips and attractions:

- Hoover Dam to see both the dam and construction of a new bridge
- Mojave desert
- Atomic testing museum actually in Las Vegas
- Automobile collection at the Imperial Palace
- Liberace museum



La última vista aérea - El Gran Cañón y el Río Colorado - 1400 millas de largo

The ultimate 'Aerial View' - The Grand Canyon and the great Colorado River - 1400 miles long.

Lo ultimo en elevacion!

Coger un helicóptero al Gran Cañón es quizás lo ultimo en elevación. Es una de las mejores experiencias de disfrutar de este magnifico paisaje - una de las siete maravillas del mundo!

Nuestro equipo de diseño, Chris, Brett y Danny han hecho la excursión en helicóptero por primera vez en febrero. La primera impresión es la que cuenta, por lo que les hemos pedido la suya, que estaba llena de "te quita el aliento, fantástico, increíble el estar allí, asombrados por el silencio que allí se respira y sobre todo...nda más que disfrutarlo". Por lo que si está pensando qué hacer cuando vaya a Las Vegas, sin duda, una vuelta en helicóptero es su plan.

Los viajes están muy bien organizados y son fáciles de reservar a través de muchas empresas locales en Las Vegas con las que puede contactar bien a través de su hotel o utilizando las páginas amarillas. Como podrá imaginar, el coste de los vuelos variará dependiendo de lo que dure el viaje y el tiempo que se pase en el Cañón.

Sundance Helicopters por ejemplo realiza cuatro viajes por día, dos por la mañana, uno a la hora de comer y uno pronto por la tarde. Por \$299 (más \$23 de recargo de combustible) tiene un viaje de tres horas y media que comienza con una limusina recogiendo en el hotel, un video de seguridad y un fabuloso viaje por el Lago Mead, la presa Hoover y el Gran Cañón, con 45 minutos sobre el suelo del Cañón, con una comida frugal con champán! El viaje de vuelta le lleva por encima de la calle principal pasando sobre la torre Stratosphere. Por \$60 más

puede adquirir el DVD de su día de excursión.

Algunos datos sobre el Gran Cañón, una de las Siete Maravillas del Mundo:

- Tiene más de dos billones de años de antigüedad.
- Con una milla (1.6km) de profundidad y 10 millas (16km) de ancho.
- Habitado desde hace 4,000 años
- Las empresas de helicópteros tienen que pagar \$1millón por año a la reserva india por el privilegio de aterrizar.
- Información y reservas o visitas al Cañón las puede hacer visitando www.xanterra.com o llamando al 888-297-2757



Man-made but impressive! The trip flies over the Hoover Dam.

Hecho por el hombre y muy impresionante! El viaje incluye volar sobre la presa Hoover

Otras excursiones de un día y atracciones:

- Presa Hoover para ver la presa y la construcción de un nuevo puente.
- Desierto del Mojave
- Museo Atómico, en Las Vegas
- Colección de Automóviles en el Imperial Palace
- Museo de la Liberación



Volando sobre el Lago Mead. Cada pasajero lleva cascos para escuchar los comentarios y hacer preguntas al piloto



LECTURA special construction branch publications

Market overview – Price-guide – Valuation

Available for Construction machinery, Forklifts, Aerial work platforms, Cranes, Loader Cranes, Construction equipment, Municipal machinery, Agricultural machinery, Recycling.

Features:

- New and second hand prices for over 75.000 machinery types
- Second hand prices of the last 15 years
- Calculation help
- Available in 6 languages

You have the choice of printed book, Online- and PDA-Version.



Directory of manufactures and dealers in China

Directory of Chinese manufactures for the sectors of construction machinery, forklift trucks and agricultural machinery



Online Dictionary

Special dictionary with machine vocabulary in 9 languages



www.lectura.de

Negotiate successfully – decide securely and well!

For all your parts... there's IPS online

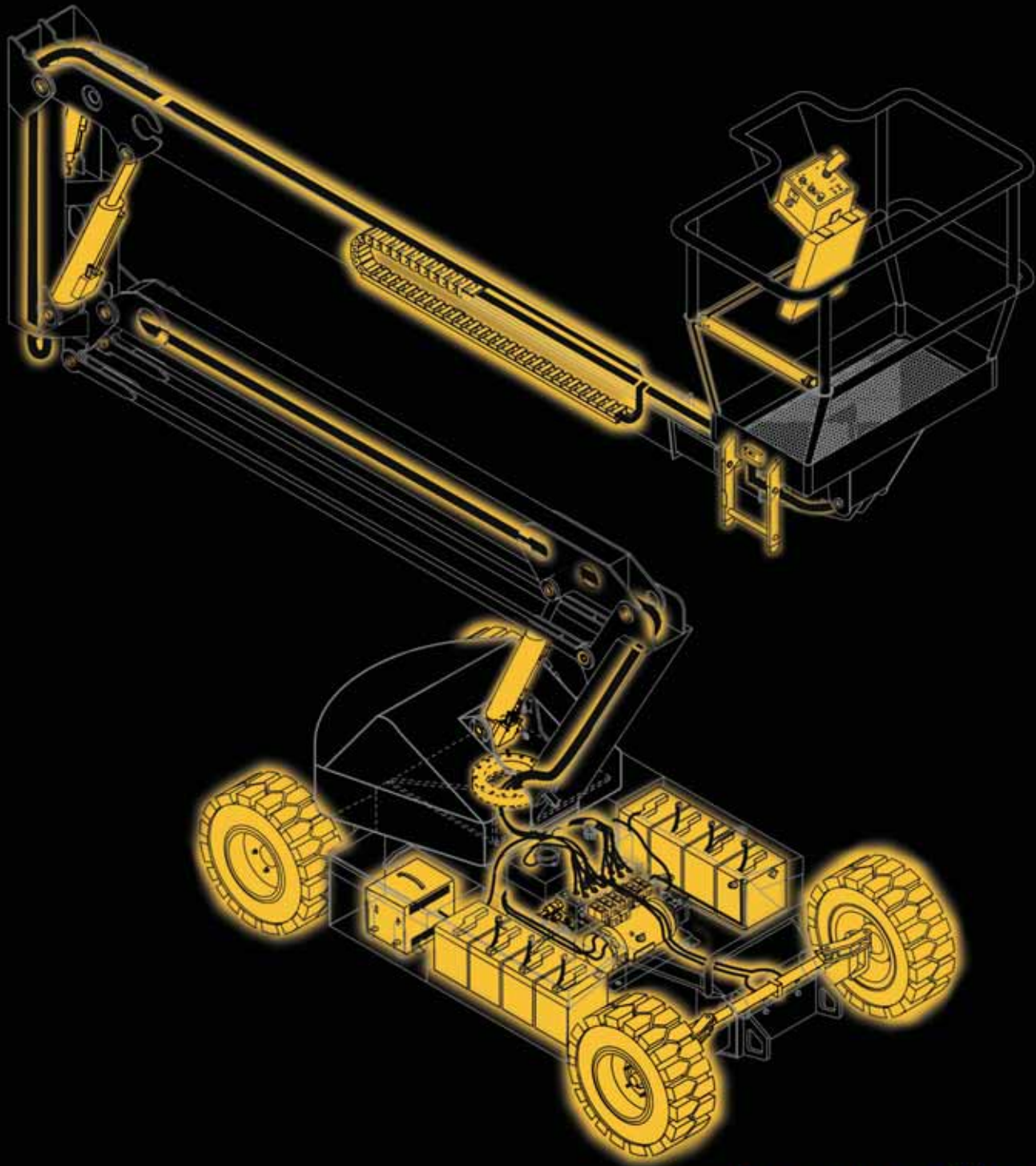

ipspartsonline.com

IPS online gives you fast and easy access to a number of services allowing you to order parts on-line, check stock availability and view our latest special offers.



IPS online 
the easy way to **access parts**

IPS UK +44 (0) 1952 607660

IPS France +33 (0) 557 24 72 11

IPS Scandinavia +358 (0) 9871 4400

IPS Australia +61 (0) 7 3902 0681

Modulift®

The Modulift System - a complete range of spreader systems made up of bolt-together components offering assembled lengths from 8" to 170ft with capacities of 2 tons to 5000 tons.



Modulift solves all your spreader requirements...

...the cost effective solution.

Modulift
NOW AVAILABLE
IN THE USA

Contact us at **+44(0)7921 141 859** or info@modulift.co.uk www.modulift.co.uk

Supply of used cranes from 25 - 800 tons

HAC Cranes GmbH & Co. KG

Tel. +49-4231-9821190 Fax: +49-4231-9821199

E-Mail: hac@hac-germany.com

Internet: www.hac-cranes.com



Supply of spare parts and crane repairs

HANSEATIC Commerz GmbH & Co. KG

Tel. +49-4231-9821180 Fax: +49-4231-9821189

E-Mail: info@hac-commerz.com

Internet: www.hac-commerz.com





BEST PARTS & MACHINERY YOUR NUMBER ONE SUPPLIER OF CRANES, CRANE PARTS AND MAINTENANCE

MACHINERY MAINTENANCE

Best Parts & Machinery B.V.
De Gorzen 4
4731 TV Oudenbosch
The Netherlands

At Best Parts we combine an experienced sales and engineering staff with an excellent customized manufacturing facility, quality workmanship and a readily available supply of spare parts to assist you in any way.

Best Parts & Machinery is official supplier for:
**TEREX, P&H, AMERICAN CRANE, SUMITOMO-HITACHI,
MANITOWOC, AND LINK-BELT PARTS**

**Biggest parts stock in Europe, AMERICAN, SUMITOMO,
LINK-BELT, MANITOWOC**

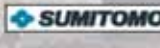
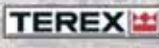

Tel.: +31(0) 165 33 22 22 Fax: +31(0) 165 33 11 20 E-mail: info@bestparts.nl www.bestparts.nl

WELEX: SPECIALIST IN EKKI MATS

Wellex is one of the oldest European companies concerned with the import and export of hardwoods and manufacturing ekki mats.

For many years we have been providing companies throughout the world with ekki mats for construction work, crane gantries, pipeline installations and bridge building.



FOR SALE
FOR HIRE

By manufacturing the mats ourselves we are able to work in an extremely cost efficient manner. We can carry out the transport, laying out and picking up of the mats for your project.

As you can see from the above, we can be of service to you in many ways. We are also pleased to assist you by providing advice and management consultancy.



Welex, Heicopperweg 38A, 4128 LP Lexmond, Holland
Phone +31(0) 347-341 215, fax +31(0) 347 342 363
E-mail: welex@welex.nl, website: www.welex.nl

This is just a
small selection
of our stock



JLG 450AJ
Year 2004
Working height 15.72 m



JLG 510AJ
Year 2004
Working height 17.81 m



JLG 600AJ
Year 2002
Working height 20.29 m



JLG 1200SJP
Year 2004
Working height 38.58 m



JLG 800AJ
Year 2002
Working height 26.38 m



JLG 3246 ES
Year 2004
Working height 11.68 m



JLG 460SJ
Year 2002
Working height 16.02 m



UpRight TM 12
Year 2004
Working height 5.80 m

Please do not hesitate to contact us as our stock changes on a daily basis.
We also have new machinery in stock, ALL major brands available.



UpRight

Only a 10 minutes drive
from Schiphol  Airport

INSTANT

HOLLAND

The address for rental and sale of Aerial platforms and Scaffolding

If You require more information call on +31 20 449 69 99
or visit www.instant-holland.nl



FORKLIFT
DIVISION



PARTS
DIVISION



HANDLING
EQUIPMENT
DIVISION



RENTAL
EQUIPMENT
DIVISION



SERVICE &
REPAIR
DIVISION



AERIAL PLATFORM PARTS

Send us your list with fast moving items and we make a quotation
150 000 references available
JLG, Genie, Haulotte, Upright, Skyjack, Diché, Grove, Dino Lift, Niftylift,...

RESPONSIBLE PURCHASE & SALES
BERNARD VANDROMME

TEL **+32 477 30 62 50**
FAX **+32 56 43 45 61**
E-MAIL **bernard.vandromme@tvh.com**

CATALOGUES:

Parts Suitable for JLG
REF12613028

Parts Suitable for Genie
REF12611647



TOTALSOURCE[®]
Parts and Accessories

USED AERIAL PLATFORMS

200 used machines in stock
JLG, Genie, Haulotte, Upright, Skyjack,
Diché, Grove, Dino Lift, Niftylift,...

RESPONSIBLE PURCHASE & SALES
WIM CARLIER

TEL **+32 56 43 45 79**
FAX **+32 56 43 43 45**
E-MAIL **wim.carlier@tvh.com**



We are continuously looking for
**PURCHASE
& SALES**
of aerial platforms
CONTACT US NOW!!!

AERIAL PLATFORMS & PARTS



www.intermat.fr

Building the future

20 to 25 April 2009

Paris-Nord Exhibition Centre - France

6 days to meet the entire construction world

INTERMAT 2009
Immeuble le Wilson
70, avenue du Général de Gaulle
92058 PARIS LA DEFENSE CEDEX - FRANCE
E-mail : intermat@intermat.fr - <http://www.intermat.fr>

INTERMAT, an exhibition organised
by the EXPOSIUM Network 
www.exposium.fr

Quality Used Access Machinery For Sale

- 30 years experience in the Access Industry
- Over 2,500 machines for sale
- All machines CE marked



Genie S125
Telescopic boom
40.1m - 2003/4/5/6



Genie Z135/80
Articulated Boom
43.1m - 2006/7



Genie GS5390
Diesel scissors
18.5m - 2005/6/7



Manitou MT2150
Diesel teleporter
21m/5tons
2004/5



Falck Schmidt FS290
Specialised spider
29m - 2003

- Machines sold tested and certified
- Lead-times a fraction of the manufacturers
- Packages/special offers available

STOCK LIST

BATTERY SCISSORS 7.6 - 17.3m

Genie GS1932	7.6m	2004/5/6/7
Genie GS2032	7.9m	2004/5/6/7
Genie GS2632	9.9m	2004/5
Genie GS2646	9.9m	2004/5/6
Genie GS3246	11.7m	2004/5/6/7
Liflux 153-12	17.3m	2001/7

Diesel Scissors 11.5m - 22.5m

Skyjack SJ6832	11.5m	2004/5/6/7
Genie GS3384	12m	2005/6/7
Skyjack SJ7135	12.5m	2007
Skyjack SJ9250	17.1m	2007
Genie GS5390	18.5m	2005/6/7
Liflux 205-25	22.5m	1999

Battery Booms 9.4m - 13.5m

Genie Z25/8	9.4m	1999/2000
Genie Z30/20n	11.1m	2005/6
Genie Z34/22n	12.5m	2004/5/6
UpRight AB38	13.5m	2004/5/7

Diesel Booms 16m - 20.4m

Genie Z45/25 BI	16m	2002/3/4/5
Genie Z45/25RT	16m	2004/5/6/7
Genie S45	15.7m	2004/5/6/7
Genie Z51/30	17.6m	2007
Genie Z60/34	20.4m	2004/5/6/7

Diesel Booms 21.8m - 43.1m

Genie S65	21.8m	2001/4/5/6/7
Genie Z80/60	26.4m	2004/5/6/7
Genie S85	27.9m	2005/5/6/7
Genie S125	40.1m	2003/4/5/6/7
Genie Z135/70	43.1m	2006/7

Specialised Access 12.2m - 42m

Nifty TD120 TN	12.2m	2007
Scanlift SL185	18.5m	2000
Scanlift SL190	19m	2001
Omme 2200RBD	21.8m	2004/6/7
Denka DL22n	22m	2001
Scanlift SL240	24m	2000/1/4
Falck Schmidt FS290	29m	2005
Falck Schmidt FS290C	29m	2005
Omme 3000RBD	29.7m	2004/6/7
Falck Schmidt FS370	37m	2005
Falck Schmidt FS420C	42m	2005

Telescopic Forklifts 4m - 21m

Manitou MT420	4m/2 ton	2002
Manitou SLT415	4m/1.5 ton	2002
Manitou MLT523	5m/2.3 ton	2004/5
Manitou MT932	9m/3.2 ton	2005
Manitou MT1030	10m/3 ton	2005
Manitou MT1335	13m/3.5 ton	2005
Manitou MT1740	17m/4 ton	2005
Manitou MRT2150	21m/5 ton	2005

Vehicle Mounted 13m - 50m

Large choice of:		
Simon S220/263/300		1987 - 1999
Bonto S34/46/50		2002 - 2005

Mini Cranes 2 - 3.5 tons

Maeda MC104 CRG	5.5m/1 ton	2006
Valla 20E	4.5m/2 ton	2003
Maeda MC285 CRME	8.7m/2.82 ton	2006
Maeda MC305 CRME	12.6m/2.93 ton	2006
Valla 35E	6.5m/3.5 ton	2003
Maeda MC405 CRM E	16.8m/3.83 ton	2007
Maeda LC785	16.35m/4.9 ton	2007

Coolquoy. The ward. Co
DUBLIN. Ireland

Tel: +353 (0)1 835 2835
Fax: +353 (0)1 835 2856

 **Easi UpLifts**
LIMITED

www.easiuplifts.com
Email: info@heightforhire.com

the access specialists

Your experienced partner in...
...powered access platforms.



- Large inventory of new machines from major manufacturers
- Machines supplied in the condition you want
- We make it easy and speak your language
- We offer OEM replacement parts for most brands
- A second to none after-sales service
- A designated division for aluminium scaffolds systems



The number 1 is
always on top!

PlatformSales
EUROPE

PlatformSales Europe • Maxwellstraat 50 • 3316 GP Dordrecht • The Netherlands

T. +31 78 65 217 65 • F. +31 78 65 217 60 • E. sales@platformsaleseurope.com • I. www.platformsaleseurope.com