



At Skyjack our philosophy is simple. We engineer lift solutions that are robust, reliable and easy to service, offering the lowest life cycle costs.



Visit us at APEX stand 1610

For information call +44-1691-676235
or visit us online at www.skyjack.com



www.skyjack.com

SKYJACK™

All access to Limburg

c&a

APEX 2011

Apex, the international powered access exhibition held every three years in Maastricht, Holland opens later this month. Now in its 15th year, the show has become a first class event for those interested in access equipment, with a full spread of products from a wide range of manufacturers.

Maastricht, the capital of the Limburg region of the Netherlands, is arguably the oldest town in Holland. The attractive city received its charter in 1204 and with Belgium to both the west and the south and Germany to the east, it was suitably cosmopolitan to be chosen for the historic signing of the Treaty on European Union, in February 1992.

The timing of this year's events could hardly be better with the market beginning to pick up and manufacturers putting their full efforts back into new products after a period when engineering resources have been soaked up by the fitting of new, cleaner engines and coping with chassis changes. The three day event is not large so it can be easily covered in a day. However if you are serious about access equipment you will want to allow at least two days in order to spend time with each exhibitor.

The following is listing of all exhibitors along with a brief preview of any new products to look out for.

'Must See' products

Airo electric booms	Moba - modular controllers
Bronto 50 metre S50 XDTJ	Movex P120TLH Hybrid
CMC TB260 26 metre truck mount	Multitel Pagliero MX250
Dino 185XTS self-propelled boom lift	Nifty Hybrids and SiOPs
Gantic battery charger	Oil&Steel Snake 2311 Compact REL
Genie GS..69 RT scissors	Ommelift 2200RB
Holland Lift N265-EL13 scissor lift	Palfinger P210 BK
Iteco Easy Up 5SP	Palfinger P300KS
InspHire mobile CMR	Skako Falcon FS520C
Isoli PNT 230	Socage N314 NAT
JLG 1500SJ	Teupen Leo 18GT Plus and Fuzzy controls.
Manitou - surprise launch	Vertikal - 'Going up in the world'

Airo Tigieffe 1500 / 3650

Italian self-propelled lift manufacturer Airo will show its two new articulated platforms, the A12JE and A15JE, both of which feature AC motor drive for travel and hydraulics for longer battery life and smoother multi-function control. The 33ft platform height industrial A12JE boom offers a working outreach of 7.5 from its 1.2 metre overall width it also boasts an articulated and rotating jib. The 45ft A15JE is 1.5 metres wide and offers 8.95 metres of outreach from its overall width of 1.5 metres.

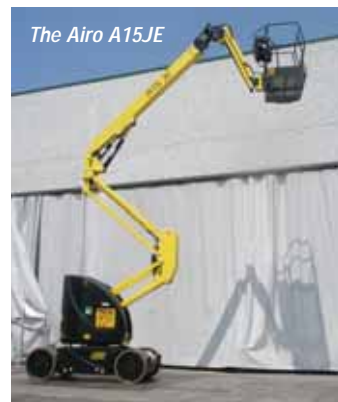

The Airo A15JE



The Cela DT21

Altrex 1110

ATN 1760 /1750

ATN produces a range of mast booms, including an unusual rubber tracked model, ideal for delicate flooring where point loadings are critical. Take a look at its Zebra 40ft articulated boom lift which offers the outreach of a 51ft unit.

Battery Supplies 1560

Belgian-based Crown battery distributor.

Big Astor 3100 / 3000

The Italian access rental company will show its patented tunnel platform device - the Tunnel Pedonale - which aims to provide overhead protection from work going on over the top of pedestrian areas.

BPE 1160

Bravi 1820

Bravi likes to keep new product launches close to its chest until the show opens. Even if it has nothing new, it will be the first chance for many to see products like its Lite and Caddy and it might show off its dry wall/plasterboard handling attachment?

Bronto Skylift 2240

Bronto will unveil an all new 50

metre S50 XDTJ, featuring a new three section telescopic jib giving an up and over outreach of 15.5 metres at about 32 metres high. Maximum platform capacity is 600kg, reducing to 120kg at the maximum outreach of 35 metres. Bronto says that the new lift will offer outreach and capacity performance equal to its current 53 metre S53XDT. The new lift will be mounted to a three axle, 26 tonne MAN truck.

CMC 3210

CMC will use the show to unveil the 'impossible' - a 26 metre working height articulated boom lift mounted on a 3.5 tonne chassis. The company says the new TB260 model will have a GVW of just 3,380kg yet offer up to 14 metres outreach and a two man platform capacity, although perhaps not at 14 metres?

Cela 1850

If you have not already seen the 21 metre Cela DT21 in the iron then waste no time and go take a look. The dual telescopic boom lift stows neatly behind the cab of the 3.5 tonne Nissan truck and yet offers an amazing working envelope.



The CTE Traccess 230

Cobo 1030

CO.ME.T. 1230

The Italian manufacturer will promote its truck, tractor mounted and road/rail lifts.

CTE 1530 / 2420

CTE will show its MP 'Multi Purpose' 20:13 truck mounted lift which works like a 13 straight telescopic or 20 metre articulated and the latest version of its popular Zed 20 model range - the Zed 20CH, the 51 metre B-Lift 510HR and its latest spider lift models, including the 23 metre Traccess 230.

Custom Equipment 1595

Custom Equipment will show its full range of compact low-level self-propelled and push-around scissor lifts. The company pioneered this market, introducing its first models well before anyone ever thought of push around scissor lifts.

D.K. Rental 1470

Part of the Lavendon Group, D.K Rental operates in France and Belgium and is Lavendon's used equipment sales operation.

Dingli 1910

The leading Chinese manufacturer of self-propelled lifts has come a long way in the past year or two and its products, particularly the smaller scissors and mast-type lifts, are definitely worth a look. It says it will have a new 40ft/12m platform height 1.2 metre wide electric scissor lift on show.

Dinolift 2110

Dinolift will unveil its very first fully self-propelled lift - the 54ft platform height 185XTS articulated Rough Terrain boom - which offers a working height of up to 18.5 metres, 250kg platform capacity and 11.7 metres of outreach. The unit incorporates four wheel drive, oscillating axle, 45 percent gradeability, 360 degrees



Dingli



The Faraone PK50S

continuous slew, 180 degrees of platform rotation and 150 degrees of jib articulation as standard. A product not to miss!

The new Dino 185XTS



The 32 metre GSRE320PXJ



Easylift 1930

Easylift has built up a solid reputation for its tracked spider lift models, but is less well known for its truck mounts. On show will be its 21 metre compact ET210 model on a Nissan 3.5 tonne chassis.

Elma 1495

Emrol 1400

Faraone 1480

Faraone builds a wide range of push around lifts, but its latest products include the ultra-compact 10ft platform height self-propelled PK50S. Just 750 mm wide by a metre long, it weighs only 290kg - lower than most push around scissor lifts - yet boasts a maximum working height of five metres.

Gantic 1795

Norwegian-based Gantic has taken a completely new look at battery charging for aerial lifts. Its chargers offer lower energy consumption, extend battery life as well as charging to their maximum capability, all thanks to its unique approach of treating each battery in a pack as an individual.



Gantic's unique battery charger

Genex 1530 / 2420

Genie Europe 1250 / 1270

While Genie may surprise us, the company is not planning to

introduce any radical new products at Apex but will show a selection from its range including its latest Rough Terrain scissor lifts introduced earlier this year. These include the GS2669, 3369 and 4069 with 26, 33 and 40ft platform heights respectively. While the new models look very similar to the models they replace, they have in fact been subject to a total redesign with numerous new features that are definitely worth closer inspection.

Giraf Track / Testcentrum De Lille 2020/3600

Giraf Track is one of those products that you should not miss. The company is carving out a strong niche for itself among users such as utilities, where its combination of high capacity, extra-large platform, tracked telehandler and crane in a package that can cross challenging terrain and level itself proves a winning combination.



The Giraf Track is something special

GSR 1920 / 3300

GSR will launch three new vehicle mounted lifts at Apex, topped by the 32 metre E320PXJ on an 18 tonne chassis with dual parallelogram risers, telescopic boom and articulated jib. It offers 280kg unrestricted platform capacity and up to 20 metres of

IMER ACCESS

Quality powered by Experience and Innovation



IMER International S.p.A.
Business Unit IMER Access
Via San Francesco d'Assisi, 8
46020 Pegognaga (MN) - Italy
Ph. +39 0376 554011
Fax +39 0376 559855
www.imergroup.com

2011
INSIDE AREA
STAND 1670
MAASTRICHT
SEPTEMBER
14-15-16



Expect a busy Holland Lift stand

Holland Lift 1450

If past shows are anything to go by Holland Lift will have the most machines per square metre of stand space. In spite of the congestion there will be much to see. Don't miss the world's largest narrow aisle scissor lift, the 86ft platform height/ 28.5 metre working height, 1.3 metre wide N265-EL13, with 750kg platform capacity and four wheel drive/steer. Also its increasingly popular XZ-60EQ124WS. Designed for the rail maintenance market the 19.8ft platform height, 1.2 metre wide unit includes 300kg platform capacity, a lateral deck extension and four wheel steer. Units are already at work in both Holland and Sweden.

I.M.A. 1480

Imer Group 1670

Imer/Iteco has much to talk about including a self-propelled version of its Easy Up 5 push around scissor lift, dubbed the Easy Up 5SP which offers a five metre work height and weighs just 490kg. Also check out its first vehicle mounted lift, a straight telescopic mounted on a 3.5 tonne Nissan Cabstar chassis.



The new Iteco self-propelled Easy Up 5SP

IMET 1139

Insa 1130

InspHire International 1790

InspHire will be demonstrating the latest version of its mobile information system which is a particularly impressive working tool when shown on an iPad, although it is equally compatible with the iPhone.

Instant Upright 1660

The Irish-based alloy tower producer will be demonstrating its



Instant towers

new web-based tower build configurator - Instant Build Kit - and new advanced guardrail and low level platforms.

IPAF 1145

IPAF is organising its fifth Europlatform conference the day before the show opens. The theme this year is Financing Growth with a number of leading speakers. The stand will highlight its campaign to educate users on the need to be aware of ground conditions under aerial lifts, including the wheels of self-propelled lifts and the outrigger pads of jacked models. You will also have the chance to purchase its latest rental market reports for both Europe and North America.

IPS 1460

The international parts and service supplier will launch several new parts catalogues, including one for replacement decals and one for controllers. The company will also be highlighting its range of outrigger mats.

Isoli 1330

The Italian truck mounted lift producer will launch two new articulated boom models, both on short wheelbase Nissan Cabstar 3.5 tonne chassis. The first is the 23 metre PNT 230 with 11 metres outreach and two position beam and jack outriggers. The sigma style dual riser provides a perfectly parallel lift up to a working height of 12 metres, with at least nine metres of clearance under the horizontal boom. The second model is the 20.5 metre PNT205LNx, which Isoli describes as a deluxe version of its

The new Isoli PNT230.

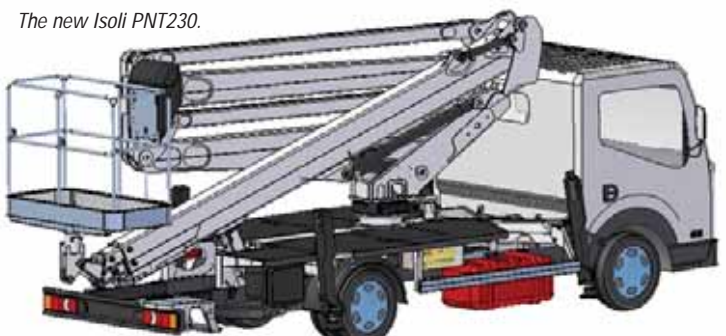

PNT 205S with 230kg platform capacity, end mounted platform (rather than pedestal mounting) and variable position outriggers.

Iteco 1670 see Imer

JCHI 1700

The Chinese-based boom and scissor lift manufacturer will show units from its growing product range.

JLG 1210 / 3010

For many visitors Apex will be the first opportunity to see JLG's new 150ft platform height 1500SJ in the iron. The world's largest self-propelled boom offers a working height of more than 47 metres and can be transported without special permits. Based on the 1350SJ it features a telescopic articulating jib which provides up 7.62 metres outreach at full boom elevation. It is also a chance to see the recently launched 34ft articulated Rough Terrain boom the 340AJ and the new smaller Toucan 8E mast boom.



The new JLG 1500SJ

outreach. The unit on display will be delivered to a Dutch customer after the show.

The second new model will be a 24 metre PX with 10 metres of outreach on a 3.5 tonne truck but few details are yet available. Finally the E170TJV is a 17 metre lift with telescopic boom and articulated jib. Mounted on an SWB 5T MB Sprinter van the unit will offer up to 1,000kg of additional payload in the van.

H.A.B. 1970

German-based heavy duty scissor and boom producer H.A.B will show models from its compact electric line including the 40ft platform height 1.2 metre wide S 142-12 E2WD and the 26ft, 1.6 metre wide S105-16 E2WD with 450kg platform capacity. Also take a look at the modular Mega platform system for its T20 and T24 telescopic boom lifts.

HL Europe 1595

Hinowa 3220 / 3430

Hinowa - the leading producer of spider lifts - will show its updated Goldlift models, the 14 metre 14:80IIS and 17 metre 17:80IIS with remote controls and auto retract outriggers. The company will also have the latest version of its Lithium Ion battery pack which it has refined significantly since it led the way with its introduction almost two years ago.

THE PEOPLE AND MATERIAL LIFTING EQUIPMENT SPECIALIST



Close to you *worldwide*

www.haulotte.com



Haulotte 
GROUP

More than lifting

Haulotte Group - La Péronnière - BP 9 - 42152 l'Horme - France - Tél : +33 (0)4 77 29 24 24 - Fax : +33 (0)4 77 29 43 95 - email : haulotte@haulotte.com



A Nagano tracked lift

Kemp Groep 1220

Kemp distributes Imer and Maeda products in Holland, and Nagano in a number of European markets. While the Nagano products are expensive, they are beautifully built and if you are looking for a large platform on the end of a boom with slew and tracks this is a stand not to miss.

Kors Hoogwerksystemen 2410

Kors sells and rents H.A.B, Omme and Skyjack in the Netherlands, and has helped develop a crawler mounted 50ft platform height telescopic boom lift for steel erection called the Bear T17J.

Leguan Lift 1600

Leguan will have a range of its machines on show and for most visitors it will be the first opportunity to meet the company's new managing director Jukka Karjalainen.



The new Multitel MX250

Manitou 1630

Manitou is saying very little about its plans for Apex apart from the fact that it will have the latest version of its 16 metre articulated boom on display, along with at least one totally new product that it says will add a new dimension to the aerial lift market.

Matilsa 1410

Matilsa will show the 18 metre Parma 1800 self-propelled boom lift with optional levelling jacks.

MavelTech 2000

MEC 1810

If you have not already seen the MEC Titan then this is another stand not to miss. The company may also show its Crossover scissor lift.



The MEC Titan boom/scissor telehandler



A 12 metre Movex P120L



Moba's new HMI Control panels

Moba Mobile Automation 1150

Moba will unveil its new HMI concept, a CAN bus-based control station with graphics, button and joystick modules that can be customised, even for low production runs. The system allows the integration of up to six modules which are linked together and to the machine via plug connections.

Movex 1420

Spanish-based vehicle mounted lift manufacturer Movex will show at least two new models, including its latest Land Rover-based lift, the 12 metre P120TL telescopic, complete

with built in storage lockers and its 12 metre battery powered Hybrid truck mount, the P120TLH on a 3.5 tonne Nissan Cabstar chassis.

Multitel Pagliero 2160 / 3200

Multitel Pagliero is celebrating its 100th anniversary this year and will unveil three new models in addition to the three it has already launched this year. The 25 metre MX250 articulated platform on a 3.5 tonne truck offers up to 12.2 metres of outreach and almost 11 metres from a height of two metres up to to almost 20 metres. A full choice of jacking configurations is available including full inboard for single lane working. The other two new models will include at least one new spider lift unit to round off its range.

Niftylift 1830

Niftylift will be focusing on its market leading innovations including its hybrid power system, SIOPs safety system and Tough cage that it is fitting to an increasingly wide



The Niftylift HR17 Hybrid



HOLLAND LIFT

ECOSTAR - Check it out ...



■ 1.00 to 1.65m wide

■ Electric powered

■ Working height
from 9.90 to 13.80m

■ Up to 450kg
platform capacity

■ Zero turning radius



■ Quality parts

+ ultra economical



www.hollandlift.com

Holland Lift International B.V.
E-mail: info@hollandlift.com

Tel: +31 (0) 229 285555
Fax: +31 (0) 229 285550

ATN

Designer & Manufacturer of Aerial Work Platforms

Visit us



Stand N°1750 + 1760
Maastricht - Hollande



www.atnplatforms.com

47400 Tonneins - FRANCE - Tel. : +33 553 761 235 - Fax : +33 553 880 107

The new Oil&Steel Snake 2311 Compact REL



range of its self-propelled lifts. Products on show will include its 120T compact 12 metre trailer lift, HR17N, HR17 Hybrid 4x4 and HR21 Hybrid AWD.

Oil&Steel 2220

Oil&Steel will launch its new 23 metre Snake 2311 Compact REL truck mounted lift on a 3.5 tonne truck. Its dual riser offers a perfectly parallel lift sequence up to an eight metre up and over height, while maximum outreach is 11 metres, with outrigger set-up completely in-board with four independently controlled straight down jacks. Also on show will be the 18 metre EVO1800 spider lift.

Ommelift 2410

Omme will have several models from its spider and trailer lift range, although a key focus will be on its 22 metre 2200RB with both AC and 400AH battery power on board. The company says that the compact machine – it is only 1.1 metre wide and just over six metres long - can drive continuously at full speed for

more than one kilometre on a single charge.

Palazzani 2310

Palazzani will have one of its new spider lifts on display and may also bring a truck mounted version of one of its straight telescopic models such as the MT32.

Palfinger Platforms 2280

Palfinger will unveil two completely new models. The 21 metre 3.5 tonne P210 BK telescopic will feature a rotating articulated jib as well as full 180 degree platform rotation. The new model, which will share the jacking and other chassis details of the P220 B and P260 B, will include a 'no-jacking' mode which will allow the jib to be rotated in order to provide lateral outreach, without the need to set up the outriggers. The second new unit will be the 30 metre working height P300 KS on a 7.5 tonne chassis which will include the 'KS' counter slewing system in order to offer ultra compact overall dimensions.



The new Palfinger P210BK.



PB Lifttechnik 2440

PB will show models from its unique levelling RT scissor lifts and heavy duty narrow aisle electric scissor lifts.

PG Trionic 2040

Platform Basket 1650

Italian spider and specialist boom lift manufacturer Platform Basket will show its 13:80 telescopic boom spider lift now available with IC plus AC power or battery plus AC power.

Power Tower 1530

Apex will be the first opportunity for the company to show its expanded range of Nano platforms and the

improved Power Tower. With new outlets in Holland, Germany, France and Austria it is now looking to step up its export sales before introducing its next range of new products.

Rima spa 1900

Ruthmann 2250 / 2435

Ruthmann will feature its 33 metre T330 truck mount on a 7.5 tonne chassis which it launched earlier



The Power Tower Nano is now available in three versions.



The new 52m Skako Falcon will feature the company's dual track system



Visit us at APEX Stand: 1250 – 1270

Three new Genie® Rough Terrain Scissor Lifts offer an upgraded industrial design with better overall performance. The new scissor family has a front active oscillating axle, which provides greater terrainability and power in extreme jobsite conditions. The entire RT69 family has been enhanced with improved jobsite performance. The new design enables all three models to drive and function at full height.

- Available in 26' (7.9m), 33' (9.96 m) or 40' (12.2m) models
- Simplified 3-4-5 link stack design
- Increased lifting capacity of up to 1,500 lbs. (680 kg) on GS™-2669 RT model
- Standard front active oscillating axle keeps all four wheels on the ground during operation
- Simplified service access with full swing out doors

+44 (0) 1476 584 333

EMAIL awp-infoeurope@terex.com | WEB genielift.co.uk

Genie
A TEREX BRAND



The Socage A314NAT.

this year. The unit offers up to 21 metres of outreach and 320kg of platform capacity, complete with a jib with 185 degrees of articulation and a full 180 degrees of platform rotation.

Scanclimber 2050

The main feature on Scanclimber's stand will be the new SC8000 heavy-duty mastclimber capable of 300 metres and up to 8,000kg platform capacity.

Skako Lift 2450 / 2290

Skako Lift, which encompasses the well-known brand names of Denka and Falck Schmidt will unveil its new 52 metre Falcon FS520C spider lift - the world's largest - in the colours of its lead customer Easi UpLifts. The unit features an eight section telescopic boom plus double articulated jib and runs on the company's well proven pivoting dual track system.

Sky Aces 1140

The Sky Aces stand will not only launch a new product, but will also celebrate the founding of an entirely new manufacturer. Sky Access is owned and managed by Paolo Balugani in partnership with Adelchi Ascari, Marco Sabbatini and Giuseppe Manenti. The first product which will be on display is the Tun Lift 737-500 designed specifically for the needs of tunnel maintenance contractors.

Sky-High 2210

The Belgian-based trailer and self-propelled lift manufacturer is increasingly focusing on specials for the rail industry and explosive environments. Well worth a stop.

Skyjack 1610

Skyjack will show a broad cross-section of its scissor and

boom range, together with its new mast-type self-propelled lift - the SJ12 and possibly its 16ft version the SJ16?

Sinoboom 1280

The Chinese manufacturer of booms and scissors is hoping to find new partners at the show as part of its move into the European market.

Socage 2030 / 2150

As we have come to expect, Socage will have a lot to talk about at Apex. The company is launching three new products, the first of which it claims is a "totally ecological compact platform" the A314 NAT installed on an AC drive Ecomile FAAM truck. At just 4.4 metres long the 13.2 metre lift is ideal for city centres and offers 360 continuous slew and full platform rotation. If an electric truck is not for you then the A314 UP version on a Piaggio Porter chassis offers the dimensions on a more traditional vehicle.

Finally look out for the 20 metre telescopic T320 on 3.5 ton Nissan Cabstar. The unit joins the T315, T316 and T318 models to top out the range, for now....

Sumner manufacturing 1385

Material lift manufacturer Sumner Lift will use Apex to launch its new Dutch-based warehouse and distribution centre.

Svelt 1690

Technobalt Eesti Oü 1120

Teupen 1430 / 2130

Teupen will unveil two new spider lifts, a new truck mount and a new 13 metre trailer lift. The spiders are the Leo15GT Plus and the Leo18GT Plus both of which build on the existing Leo GT products, but incorporate new stabilisers and an articulating jib. The new Leo18



The Skyjack SJ12

superstructure has also been adapted for the EuroB18GT to provide 18.8 metres of working height and 8.5 metres outreach with a total GVW of 3,240kg and overall height of 2.35 metres.

Time International 2010 / 2120

Time will show models from its Versalift range of van and truck mounted lifts including its increasingly popular hybrid and semi hybrid models and new van mount stabilisers.

Trojan Battery 1040

TVH 1570

The Belgian-based parts supplier recently acquired Gunco/HDW, will launch brand specific parts catalogues for Genie, JLG and Haulotte.

US Battery 1800

Verhuurnet/RentalCheck 1695

Vertikal.Net 260

Make sure you stop by the stand and learn about the latest developments on Vertikal.net and also to pick up a copy of Denis Ashworth's new book on the access industry.

Vertimac 1470

Essential info:

Venue:
MECC Maastricht Forum 100
6229 GV Maastricht The Netherlands
Tel.: +31(0)43 383 8383
Fax : +31(0)43 383 8300

Dates & Opening Hours:
Wednesday Sept. 14 09.30 - 18.00 h.
Thursday Sept. 15 09.30 - 18.00 h.
Friday Sept. 16 09.30 - 17.00 h.



The new Teupen Leo 18GT Plus.



Reach higher. On all levels.

The new JLG® 340AJ 4WD articulating boom lift **escalates performance** levels. Developed for a broad spectrum of construction applications, it offers a full 12,35 m working height as well as **enhanced terrainability**. It is durable and versatile, specifically designed for easier maintenance and efficient fleet management. **Raise your expectations.** Count on the JLG 340AJ and JLG customer service to reach farther so you can **go higher**.

JLG. Helping you reach your potential.

JLG